

~~SECRET~~

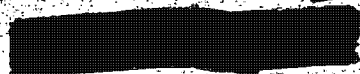

NR025X1A1(I)C

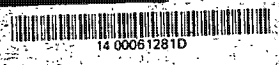

BEST COPY AVAILABLE

NR025X1A4(I)C

1004

CORONA J FLIGHT REPORT

FTV 1174 - J5

NR025X 1626 J.C.

PREPARED BY

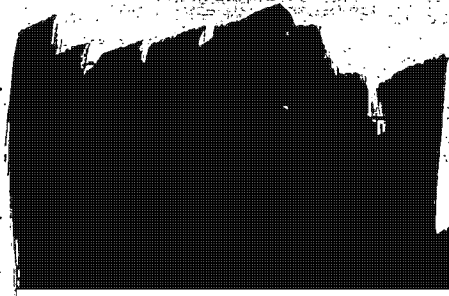

DATE 3/3/69

APPROVED BY

DATE 3/8/69

APPROVED BY



DATE 3-9-69

NR025X1A4(I)C

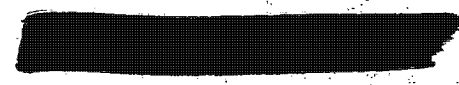

~~SECRET~~

NR025X1A4 (1)C

NR025X1A1 (1)C

TABLE OF CONTENTS

SUMMARY

INSTRUMENTATION AND COMMAND PERFORMANCE

CAMERA SETTINGS AND FILM TYPES

PANORAMIC CAMERA PERFORMANCE

STELLAR INDEX OPERATION

CLOCK PERFORMANCE

RECOVERY SYSTEM PERFORMANCE

First Recovery System

Second Recovery System

REACTIVATION PHASE PERFORMANCE

THERMAL CONTROL SYSTEM PERFORMANCE

APPENDICES

NR025X1A4 (1)C

~~SECRET~~

NR025X1A1(I)C

SUMMARY

NR025X1A4(I)C

Flight Test Vehicle No. 1174 was a SLV-2A/01A combination, booster and orbital stage launched from Vandenberg Air Force Base at 1:38:24 P.M. PST on 15 February 1964. A dual recovery reconnaissance camera system consisting of panoramic cameras 124 and 125 and stellar index cameras D29/29/29 and D42/42/37 was the primary payload aboard.

Ascent and injection into orbit were normal with the exception of a slow closure of a fuel valve causing a tail off velocity of 27 feet per sec. instead of the predicted 7 feet per sec. This resulted in orbital parameters that were beyond 3 sigma.

Table I is a comparison between the actual and predicted orbital parameters.

TABLE I

ORBITAL PARAMETERS (Orbit 1)

<u>Parameter</u>	<u>Predicted</u>	<u>Actual</u>
Period (Minutes)	90.67	90.92
Apogee (N.M.)	234.65	249.7
Perigee (N.M.)	100.5	99.9
Eccentricity	0.0186	0.0207
Inclination (degrees)	75.0	74.97
Perigee Latitude (degrees)	23	29

A two phase 7 day camera operational mission with no deactive period between phases was programmed. The first phase was completed and a successful air catch recovery of the capsule was made on orbit 49 on 18 February 1964. The second phase of the mission was completed on orbit 112 on 22 February 1964 with a successful air catch recovery of the second capsule.

NR025X1A4(I)C

~~SECRET~~

~~SECRET~~

NR025X1A4(I)C

An evaluation of the payload system operation as derived from telemetry data is included in the following sections of this report.

INSTRUMENTATION AND COMMANDER PERFORMANCE

The instrumentation system performance was satisfactory throughout both phases of the mission.

Several command anomalies occurred during the flight, all at the ~~██████████~~ Tracking Station during the transmission of AP Analog commands nine (program select) and six (V/H Ramp Level). Command nine anomalies occurred on orbits 7, 22, 29, 39, 55, 70 and 101. A command six anomaly occurred on orbit 102. On all of these passes the command selector either advanced past the desired position or did not advance as commanded. In all cases additional commands were issued to advance the selectors to the desired position prior to fade. The payload system operation or performance was not impaired by these commanding anomalies. However, this problem has occurred on the past several flights and the potential of incorrect program execution exists. Corrective action should be taken at the ~~██████████~~ ~~██████████~~ as command difficulties are not being experienced at the other tracking stations in the network. This indicates the problem is station peculiar.

Was...

NR025X1A4(I)C

CAMERA SETTINGS AND FILM TYPES

Table II is a tabulation of the pertinent camera settings and film types used on this mission.

TABLE II

CAMERA SETTINGS AND FILM TYPES

Panoramic Cameras:	<u>Master</u>	<u>Slave</u>
Film Type	SO-132	SO-132
Slit Width	0.250	0.250
Filter Type	Wratten 21	Wratten 21

NR025X1A4(I)C

~~SECRET~~

~~SECRET~~

NR025X1A1(I)C

Horizon Optics:

NR025X1A4(I)C

	<u>Master</u>		<u>Slave</u>	
	<u>Take-up</u>	<u>Supply</u>	<u>Take-up</u>	<u>Supply</u>
Aperture	F8.0	F6.8	F6.8	F8.0
Exposure Time	1/100 sec.	1/100 sec.	1/100 sec.	1/100 sec.
Filter Type	Wratten 25	Wratten 25	Wratten 25	Wratten 25

Stellar Index

	<u>Stellar Index A</u>		<u>Stellar Index B</u>	
	<u>Stellar</u>	<u>Index</u>	<u>Stellar</u>	<u>Index</u>
Film Type	SO-102	SO-130	SO-102	SO-130
Aperture	F1.8	F4.5	F1.8	F4.5
Exposure Time	2 Sec.	1/500 sec.	2 Sec.	1/500 sec.
Filter Type	None	Wratten 21	None	Wratten 21

PANORAMIC CAMERA PERFORMANCE

Both panoramic cameras operated throughout the mission. Camera operation was monitored on telemetry on 15 passes during the flight. The only dynamic operational anomaly evident was on the first operation after cut and wrap. On this operation (pass 49) the supply idler on the slave camera indicated uneven metering during slowdown at system turnoff. Enclosure 1 is an analog telemetry record showing turnoff during this pass.

A lens stow operation of 4 frames was run on orbit 11 prior to turning on the V/H programmer. Telemetry data indicated both lenses stowed with a cycle period of approximately 8 seconds per cycle.

The cut and wrap operation appeared normal with both lenses stopping in the home or stowed position. All switchover functions occurred as programmed.

NR025X1A4(I)C

~~SECRET~~

~~SECRET~~

NR025X1A1(I)C

Variations of the cycle period repeatability were evident throughout the mission with maximum errors of 4.4 and 4.2 percent for the master and slave instruments respectively. These errors are very similar to the errors noted during pre-flight testing of this system. A tabulation of the cycle period data and the percent error from the programmed cycle periods are included in Table III.

NR025X1A4(I)C

TABLE III

CYCLE PERIOD DATA

<u>Orbit</u>	<u>Time Up Ramp</u>	<u>Master</u>			<u>Slave</u>		
		<u>Nominal</u>	<u>Actual</u>	<u>Percent Error</u>	<u>Nominal</u>	<u>Actual</u>	<u>Percent Error</u>
1	1900	2.500	2.480	0.80	2.517	2.500	0.68
9	650	5.930	6.012	1.4	5.971	6.045	1.25
11	0	7.930	8.080	1.89	8.000	8.350	4.37
25	685	5.778	5.888	1.9	5.817	5.936	2.04
31	2290	2.267	2.293	1.1	2.284	2.317	1.4
33	2475	2.260	2.330	3.1	2.277	2.365	3.86
41	735	5.563	5.491	1.3	5.600	5.584	0.3
47	2365	2.256	2.300	1.95	2.273	2.286	0.57
49	2525	2.269	2.325	2.47	2.286	2.350	2.8
57	1425	3.337	3.420	2.49	3.354	3.470	3.46
61	2300	2.264	2.310	2.03	2.281	2.330	2.1
78	2350	2.257	2.305	2.12	2.274	2.335	2.68
94	2500	2.264	2.335	3.1	2.281	2.355	3.2
104	950	4.711	4.730	0.44	4.739	4.810	1.5

~~SECRET~~

~~SECRET~~

NR025X1A4(1)C

NR025X1A1(1)C

The overall film consumption indicated the camera system was running approximately 1% slow. The V/H ramp level was changed after orbit 94 to increase the cycle rates.

No other dynamic problems were evident in the telemetry data.

Reportedly, the processed film indicated the master camera was slow in coming up to speed on passes after orbit 72. Telemetry data for the engineering passes was reviewed. Both the master and slave turn on characteristics were very similar, with the slave instrument being approximately 1% slower than the master instrument over the entire operation on all engineering passes. The slow turn on of the master instrument was not evident in any engineering pass data for either phase of the mission.

STELLAR INDEX OPERATION

Stellar index operation appeared satisfactory during both phases of the mission. Stellar index operations were monitored on orbits 1, 9, 25, 31, 33, 41, and 47 on the first phase of the mission and on orbits 49, 57, 61, 78, 94, and 104 on the second phase of the mission. All shutter opening and metering functions appeared normal for both stellar index cameras.

CLOCK PERFORMANCE

Clock operation appeared normal with the time accuracy within the reading accuracy of the analog records used for correlation.

RECOVERY SYSTEM PERFORMANCE

First Recovery System:

A successful air catch of the capsule was made on orbit 49. The point of impact was approximately 85 miles downrange and 25 miles east of the predicted impact point. Analysis of the telemetry data indicates no apparent anomalies that would have caused this dispersion. All capsule re-entry

NR025X1A4(1)C

~~SECRET~~

~~SECRET~~

NRO25X1A4(I)C NRO25X1A1(I)C

events occurred within tolerance and receiver signal strength data indicates clean separation, spin, and retro events. Vehicle attitude data indicates correct attitude at separation and the re-entry trajectories have been reviewed. Further analysis is continuing.

The condition of the recovered capsule was satisfactory with damage limited to normal paint blistering. Enclosures 2, 3 and 4 are diagrams showing re-entry temperatures. Post flight inspection and testing revealed no anomalies.

NRO25X1A4(I)C

Capsule telemetry was acquired at both the [redacted] stations with good coverage of the retro events by both stations. Table IV is a tabulation of the sequence of re-entry and recovery event times.

TABLE IV
RECOVERY SEQUENCE OF EVENTS

<u>Event</u>	<u>System Time</u>	<u>Delta Time</u>	
		<u>Actual</u>	<u>Nominal</u>
Transfer	85777.40		
Elect. Disc.	85778.31	.91	.90 + .430 .400
Separation	85779.40	2.0*	2.0 + .25
Spin	85781.53	3.25**	3.4 + .30
Retro	85789.02	7.49	7.55 + .45
De-spin	85799.91	10.89	10.75 + .54
T/C Separation	85801.41	1.50	1.5 + .15
"G" Switch Open	86307.23	-	-
Parachute Cover Off	86340.06	32.83	34.0 + 1.5
Drogue Para. Deployed	86340.77	0.71	0.75 + .08
Drogue Para. Released	86351.35	10.58	10.05 + 1.0
Main Para. Deployed	86352.16	0.81	1.2 + .15
Main Para. Disreefed	86356.27	4.11	4.0 + 1.7

NRO25X1A4(I)C

~~SECRET~~

~~SECRET~~

NR025X1A4(I)C

NR025X1A1(I)C

- * From Transfer
- ** From Electrical Disconnect

Spin Rate	66.2 PRM
De-spin Rate	8.4 RPM (Data Questionable)
Retro Velocity	950 FPS
Recovery Battery Voltage at Arm	14.5 Volts

Second Recovery System:

The temperature sensor installed on the dreamboat battery indicated a temperature of approximately 60 degrees (enclosure 11) prior to actuation of the battery heaters at first recovery on orbit 49. At the next real-time acquisition (orbit 56) this sensor indicated 104 degrees. The temperature stabilized at 100 to 104 degrees for the remainder of the flight as indicated by this monitor. Temperature data was recorded for approximately one-half an orbit for orbits 50, 51, 52, and 53. These data have been plotted and are included as Enclosure 5. They indicate a constant increase in temperature until stabilization near the end of orbit 53 with no fluctuations indicative of thermostatic action. Tape recorded data on these and other orbits indicated self-heating of the temperature sensor of about 4 to 8 degrees. This has not been subtracted from the above data or from data plotted in Enclosure 5.

From an evaluation of the data, it appears that the battery temperature did not actually reach the 95 degrees required for the thermostat to shut off the heaters. An analysis indicates that by subtracting the observed self-heating and by applying any other instrumentation tolerances

NR025X1A4(I)C

~~SECRET~~

~~SECRET~~

[REDACTED]

NRO25X1A4(I)C

NRO25X1A1(I)C

[REDACTED]

coupled with the low internal system temperatures, the required 95 degree temperature was not reached.

Post-flight testing of the battery indicated proper thermostat action with turn on at 65 degrees and turn off at 95 degrees. A post-flight calibration of the temperature sensor was made and compared favorable to the calibration used in flight. See Enclosure 6.

A successful air catch recovery of the capsule was made on orbit 112. The impact point was within the tolerances of impact prediction.

NRO25X1E1(I)C

Telemetry data for the retro events acquired [REDACTED] as noisy and events prior to retro were not monitored. Retro, de-spin and thrust cone separation appeared normal. Telemetry data for the parachute deployment events indicated normal deployment. Table V is a tabulation of the recovery event times.

TABLE V

RECOVERY SEQUENCE OF EVENTS

<u>Event</u>	<u>System Time</u>	<u>Delta Time</u>	
		<u>Actual</u>	<u>Nominal</u>
Retro	83410.5 ± 0.1	-	-
De-Spin	83421.4 ± 0.1	10.90	10.75 ± .54
T/C Separation	83422.2 ± 0.1	0.80	1.5 ± .15
"G" Switch Open	83934.00	-	-
Parachute Cover Off	83967.62	33.62	34.0 ± 1.5
Drogue Parachute Deployed	83968.22	0.60	0.75 ± .08
Drogue Parachute Release	83977.86	9.64	10.05 ± 1.0
Main Parachute Deployed	83978.67	0.79	1.2 ± .15
Main Parachute Disreefed	83983.28	4.61	4.0 ± 1.7
Spin Rate	66.6 RPM		

NRO25X1A4(I)C

[REDACTED]

~~SECRET~~

~~SECRET~~



NR025X1A4(I)C

NR025X1A1(I)C



The physical condition of the recovered capsule was satisfactory. However, minor scratches were evident directly below the normal resting position of the capsule on the forebody forward guides.

Enclosures 7, 8 and 9 are diagrams showing re-entry temperatures encountered.

NR025X1E1b, JIC

REACTIVATION PHASE PERFORMANCE

Deactivation was commanded on orbit 112 at the  Station after second recovery. The vehicle was deactive until orbit 269. Reactivation was commanded on orbit 269 and was successfully achieved. Battery power was marginal and was not sufficient to permit restabilization. The payload system was programmed to operate on orbit 277; however, the batteries were depleted approximately 20 seconds prior to this operation.

THERMAL CONTROL SYSTEM PERFORMANCE

The space structure for Flt. 1174 (J-5) was painted to provide critical camera subsystem component temperatures according to the requirements of SP2-478, "J Program Requirement Specifications".

The J-5 paint pattern was based upon preliminary parametric thermal analyses conducted by LMSC utilizing an incomplete thermal model of the physical system and flight data observed during M-25, M-26 and J-2 Missions.

The basic external thermal control surfaces were silicone silastic and vapor deposited gold as shown:

NR025X1A4(I)C



~~SECRET~~

~~SECRET~~



NR025X1A4(I)C

NR025X1A1(I)C

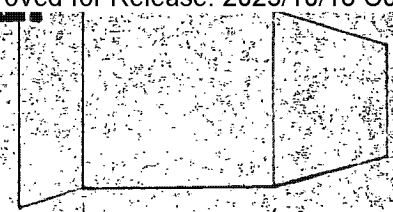

34% 34% 42% Silicone Silastic
 66% 66% 58% Gold

The exception to the above pattern was in the area of the index camera where a larger percentage of black paint was used on this vehicle than on previous vehicles.

The external cover surfaces, where feasible, of both S/I's were covered with Mystic tape in order to increase the S/I temperature related to data taken on the previously-mentioned missions.

The design for this vehicle was based upon an initial B range of -46° to -32°.

A system of temperature sensor identification is used throughout this report which incorporates abbreviations. The general identification form is:

X - A - Y

where:

X defines the first or second system number, as the case may be,

A defines the system

Y defines the temperature sensor number

i.e.

2 I - 4 is the No. 2 instrument temperature sensor 4

1 B - 5 is No. 1 barrel temperature sensor 5

NR025X1A4(I)C



~~SECRET~~



NR025X1A4(I)C



NR025X1A1(I)C

The following abbreviations for A were used:

- F - Fairing
- B - Barrel
- CL - Clock
- C - Take-Up Cassette
- AI - Agena Interface
- SC - Supply Cassette
- I - Instrument
- S/I - Stellar Index Camera
- TC - Thrust Cone
- BAT - Dreamboat Battery (Recovery Pattery)

NR025X1E6, I, C

A tabulation of the real-time temperature data acquired at the



is included as Enclosures 10 and 11.

The Appendix contains tape recorded thermal data for orbits 0, 1, 22, 39, 72, 85 and 101. The orbital 4th power average values for the skin sensors and the instrument sensors were used as input to a computer program which calculates the orbital station average skin temperature (\bar{T}) and computes an indicated temperature gradient across the inside of the barrel. The results of these computations are presented in Enclosure 21, which is a plot of skin station \bar{T} , barrel center average temperature, (T_{ic}) minimum and maximum internal temperatures vs. orbit number. Enclosure 22 is a plot of sun angle (B) vs. orbit number. Enclosure 23 is a cross plot of skin \bar{T} and T_{ic} vs. B .

NR025X1A4(I)C



~~SECRET~~

NR025X1A4(I)C

NR025X1A1(I)C

These data have been corrected for self-heating per empirical data derived from a special self-heating test conducted in pre-flight environmental testing and confirmed by orbital tape recorded data. The micro system transducer self-heating curve was obtained in laboratory testing and is presented as Enclosure 12. The self-heating testing for BN 2400 transducers consisted of soaking the payload system for approximately 12 hours at ambient temperature and simulated altitude without excitation voltage on the temperature transducers. Telemetry recorders were turned on simultaneously with the excitation voltage and the temperature data was monitored for 90 minutes. These data are presented in Enclosure 13. The self-heating curves obtained in this testing were compared with on-orbit tape recorded data for one complete orbit, orbit 23, and found to be identical with the exception of the thrust cone, dreamboat battery, supply spool, cassette, and camera No. 2 - I 9 sensors. Curves for these sensors have been adjusted accordingly.

It is felt that the temperature data for J-5 is the most accurate thermal data presented to date. The J-5 self-heating test provided individual sensor self-heating corrections based upon installed configuration under simulated orbital conditions. Analysis of apparent self-heating characteristics as demonstrated in flight confirmed the self-heating curves. Analysis of the final tape recorded data presented in this report confirm the accuracy of the self-heating curves. The presented data indicate no significant temperature change at the same latitude on successive orbits; i.e., compare the

NR025X1A4(I)C

~~SECRET~~



NR025X1A4(1)C

NR025X1A1(1)C



first and second to last points presented for each parameter. These data were corrected for self-heating as a function of time from instrumentation on command. Any error in the correction curve will manifest itself as a difference between the two points noted. Furthermore, compare the 4th power averages of all instrument sensors; they appear reasonably close to one another. The computer routine used to calculate the apparent thermal gradient across the inside of the barrel assumes the internal mass to be a thermally homogeneous slug. The standard deviations of the curve fits to the instrument sensor data were, on the average, approximately 3.9°F. This standard deviation is considered well within the expected values considering the inaccuracies of the basic assumptions. Again this relationship lends credence to the relative accuracy of the individual instrument sensor calibrations.

The advent of self-heating corrections has caused some confusion to those not intimately involved in the processing of thermal data. For this reason, the following history of self-heating correction application is presented:

- Prior to J-1 Self-heating unknown - no correction applied.
- J-1 Bias of 10°F to instrument sensors only.
- J-2 Use of a single time function curve based on lab test. Curve asymptotic at 14°F.
- M-25, M-26 Use of a single time function curve based on analysis of orbital tape recorded data. Curve asymptotic at 6°F.

NR025X1A4(1)C

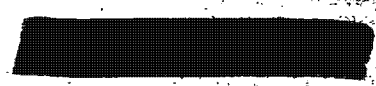

~~SECRET~~

NR025X1A4(I)C

NR025X1A1(I)C

J-5 Use of individual sensor time function curve based upon vehicle environmental test and confirmed by analysis of orbital tape recorded data. Curves varied in asymptote from 29°F to 4°F. The bulk of instrument sensors corrected by use of curve asymptotic at 12°F.

There was no significant overall system temperature error for the payloads for which corrections were applied; however, significant errors for individual sensors did exist prior to J-5. Prior to J-1, the tape recorder was not used and the instrumentation was on for short times when data points were hand reduced and presented in the flight reports. Except for TS-11, the self-heating errors prior to J-1 were probably not significant.

On the basis of these data, it is felt that the self-heating corrections applied to the temperature data is accurate within + 3 degrees.

Calibration Curves were made for each individual temperature sensor using measured divider and sensor resistance values wherever possible.

Enclosures 14 through 20 show the temperature sensor locations for the system.

The following temperature sensors are switched at the time of first recovery:

NR025X1A4(I)C

~~SECRET~~

~~SECRET~~

NR025X1A4(I)C

NR025X1A1(I)C

1. First recovery system thrust cone to second recovery system thrust cone.
2. Stellar index No. 1 to stellar index No. 2.
3. Fairing sensors to barrel No. 1 sensors.

NR025X1A4(I)C

~~SECRET~~

SECRET

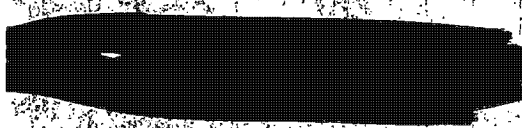
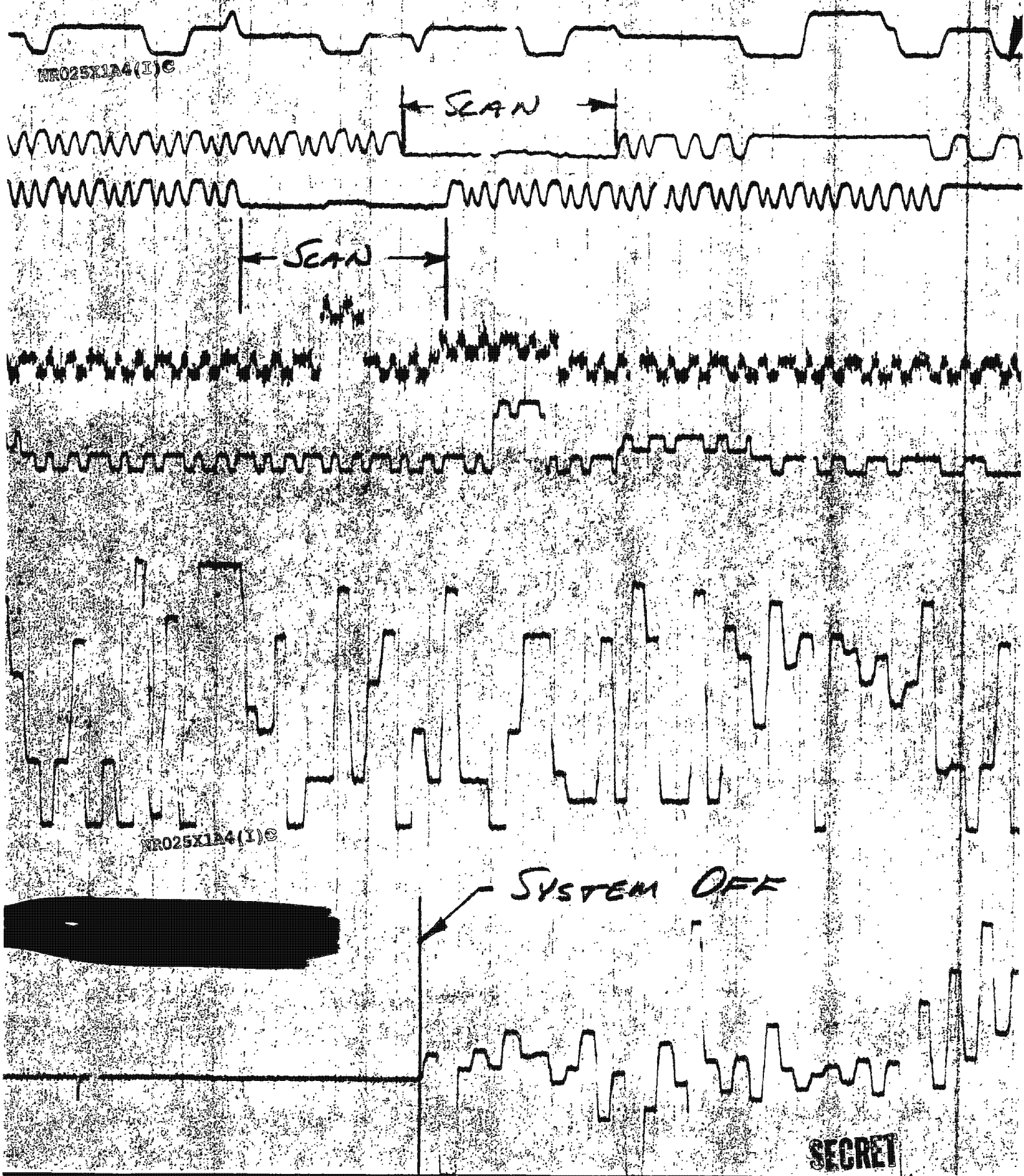
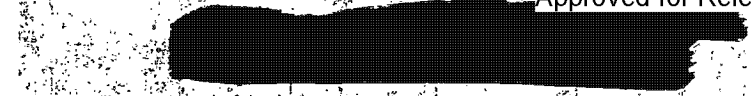

SECRET

CASSETTE ROTATION NR025X1A4(I)C

1174-95 ORBIT 4



SLAVE SUPPLY IDLER (UNEVEN METERING)



MASTER SUPPLY IDLER

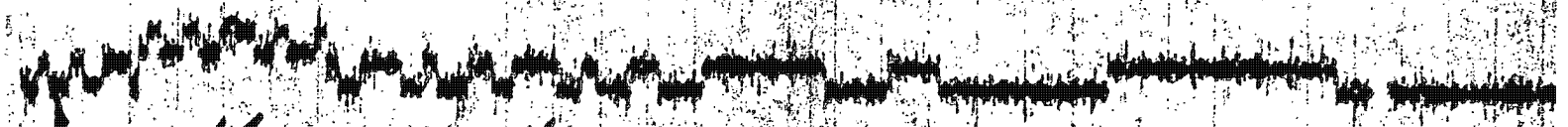

MASTER HORIZON IDLER



SLAVE HORIZON IDLER

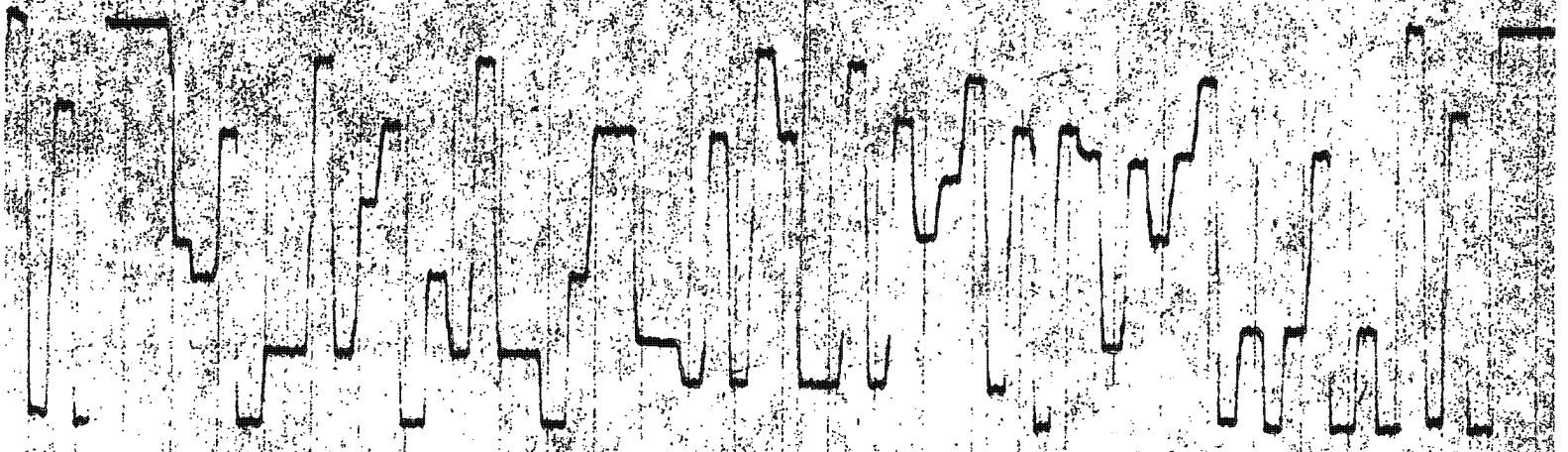

NR025X1A4(I)C

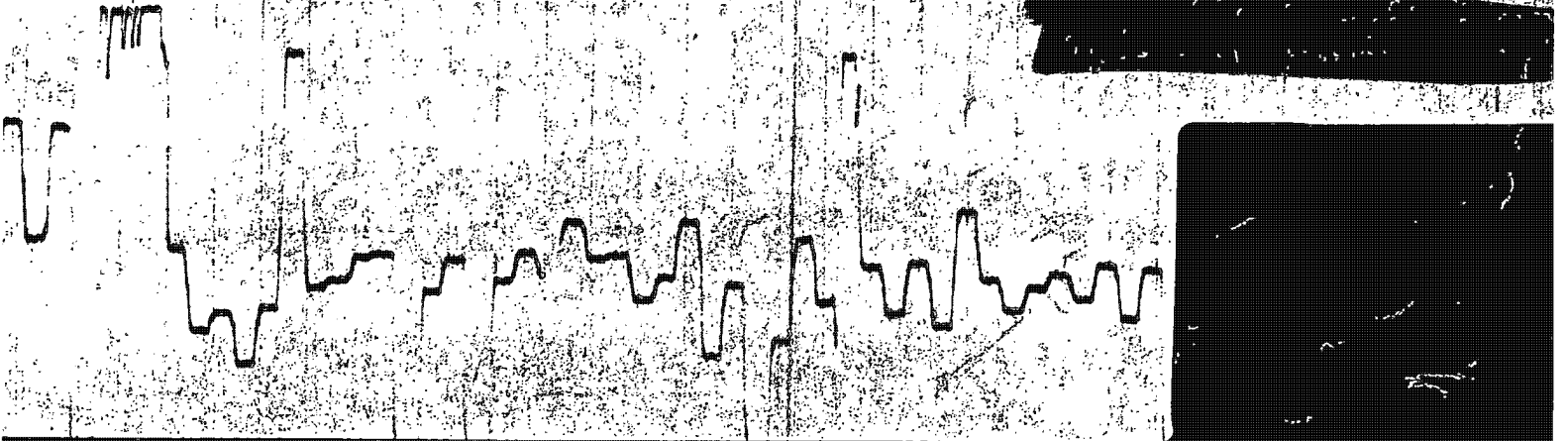
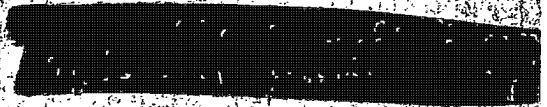

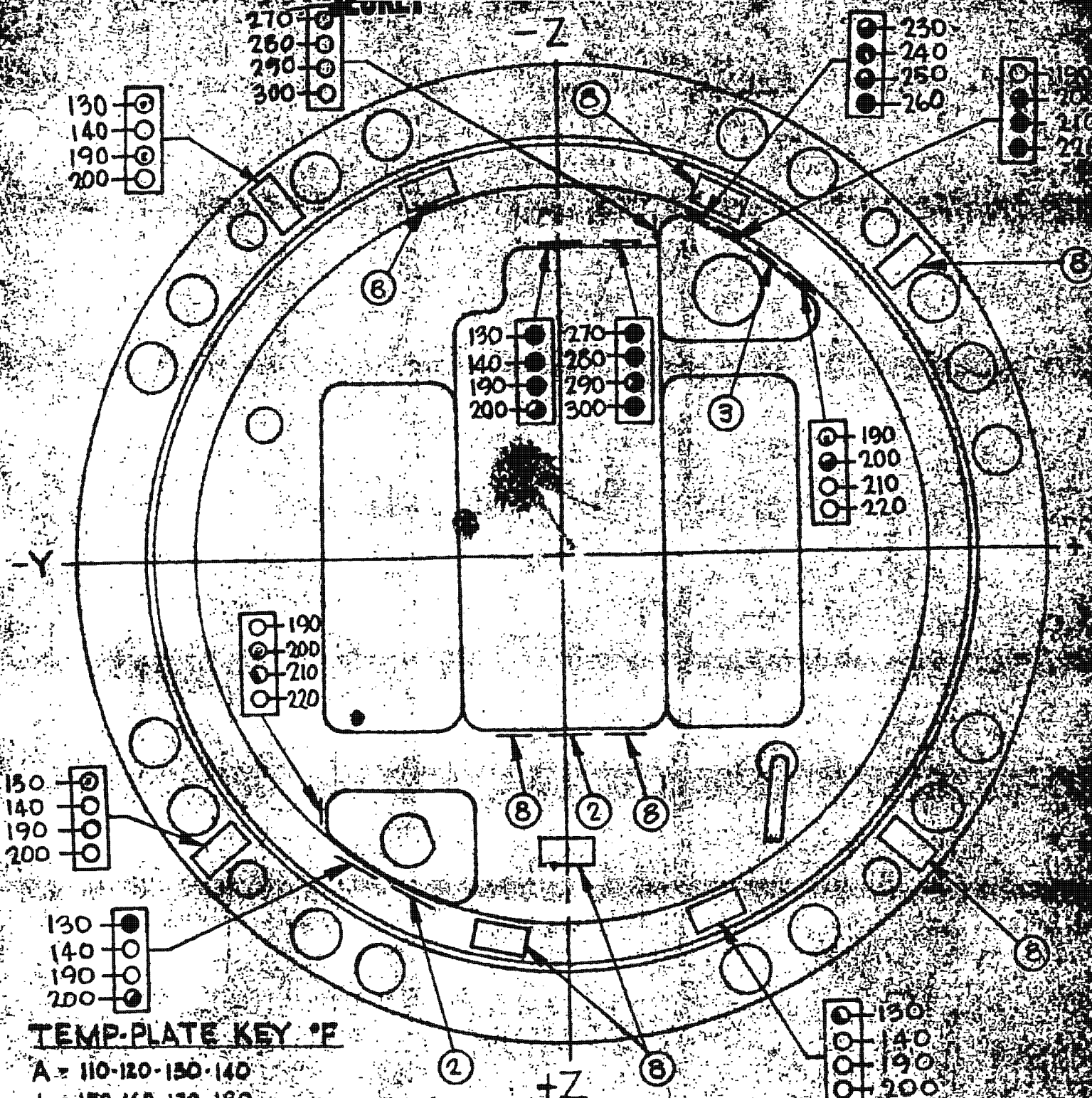

TEMP-PLATE KEY 'F'

- A - 110-120-150-140
- 1 - 150-160-170-180
- 2 - 190-200-210-220
- 3 - 230-240-250-260
- 4 - 270-280-290-300
- 5 - 310-320-330-340
- 6 - 350-360-370-380
- 7 - 390-410-435-450
- 8 - 130 140 190 200

LOOKING FORWARD
VEHICLE 1174

● INDICATOR TURNED BLACK
TEMP REACHED OR EXCEEDED
INDICATED LEVEL

J5 A

~~SECRET~~

ENCLOSURE 2

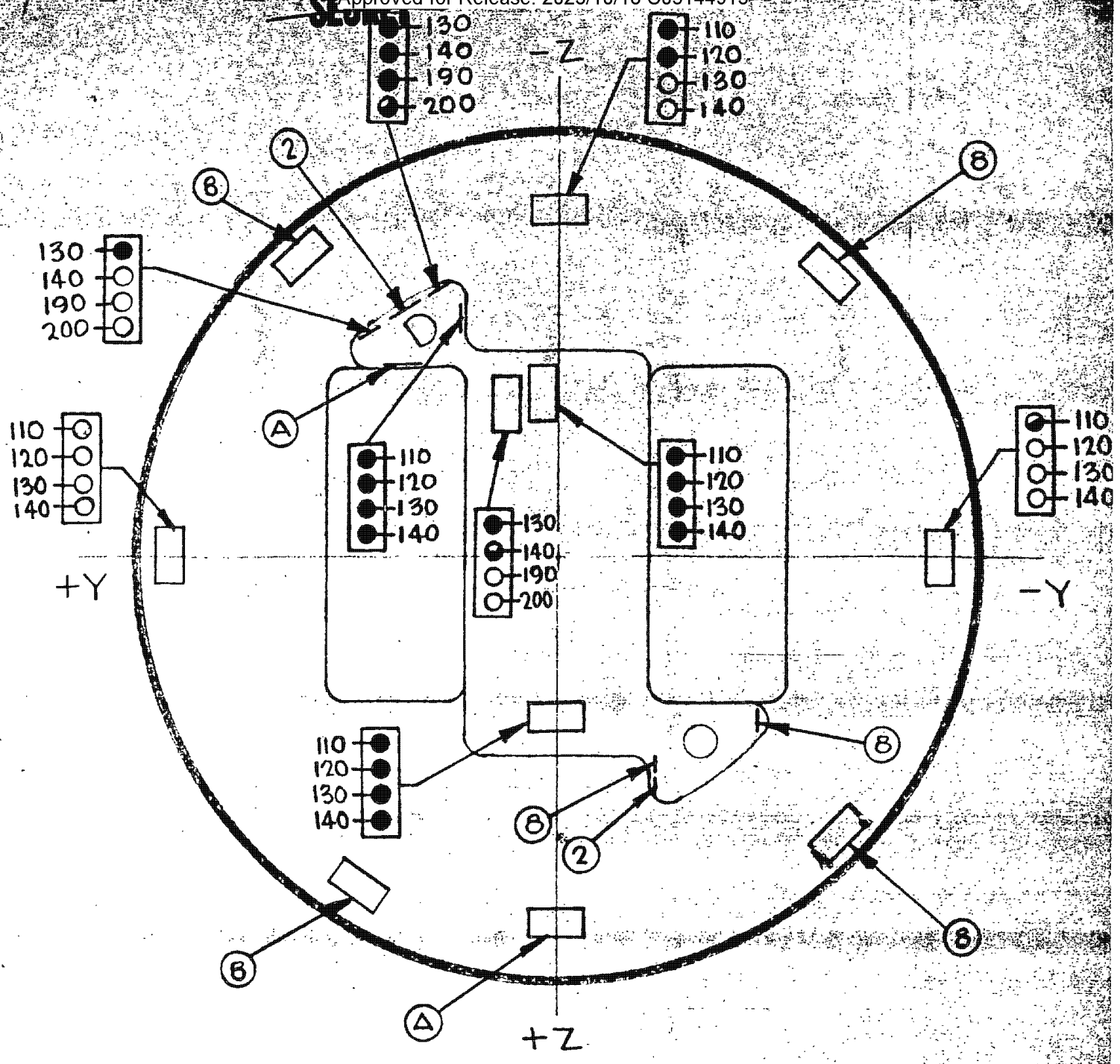

LOOKING AFT
 VEHICLE 1174
 USE OF TEMP-PLATES)

TEMP-PLATE KEY °F

- A- 110 · 120 · 130 · 140
- 1- 150 · 160 · 170 · 180
- 2- 190 · 200 · 210 · 220
- 3- 230 · 240 · 250 · 260
- 4- 270 · 280 · 290 · 300
- 5- 310 · 320 · 330 · 340
- 6- 350 · 360 · 370 · 380
- 7- 390 · 410 · 435 · 450
- 8- 130 · 140 · 190 · 200

● INDICATOR TURNED BLACK
 TEMP REACHED OR EXCEEDED
 INDICATED LEVEL

SECRET 15 A

ENCLOSURE 3

~~SECRET~~

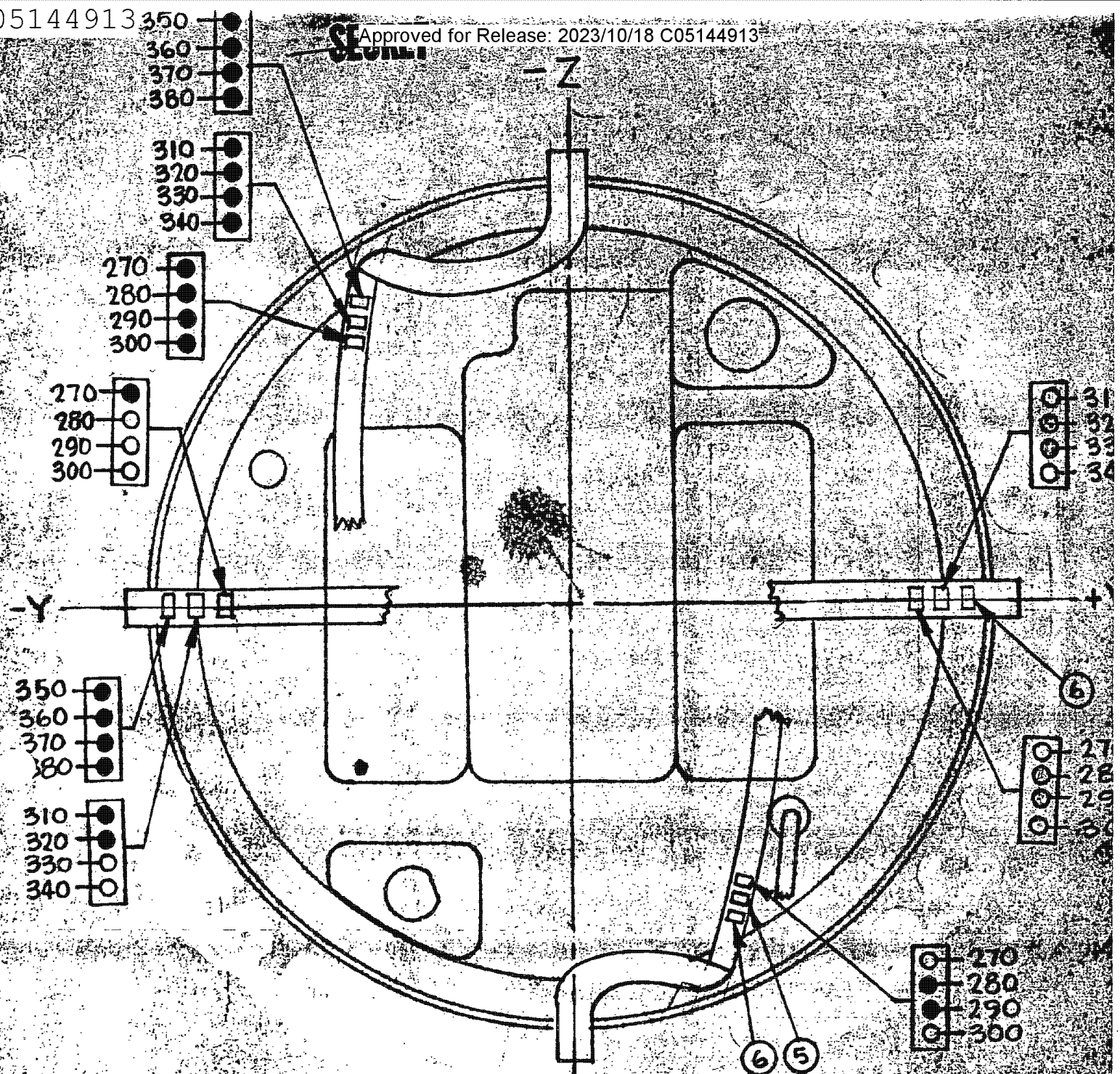

TEMP-PLATE KEY °F

- A - 110-120-130-140
- 1 - 150-160-170-180
- 2 - 190-200-210-220
- 3 - 230-240-250-260
- 4 - 270-280-290-300
- 5 - 310-320-330-340
- 6 - 350-360-370-380
- 7 - 390-410-435-450

LOOKING FORWARD
 VEHICLE 1174
 USE OF TEMP PLATES
 ON PARACHUTE SHROUDS.

● INDICATOR TURNED BLACK
 TEMP REACHED OR EXCEEDED
 INDICATED LEVEL

J5A

~~SECRET~~

ENCLOSURE 4

NR025X1A4(I)C K&E 10X 10 TO THE INCH KEUFFEL & ESSER CO. MADE IN U.S.A. 359-5

1174 - F-5 RECON SYSTEMS
DREAMBOARD DATA
TEMPERATURE
TAPE RECORDED DATA
NO SELF HEATING & BIAS

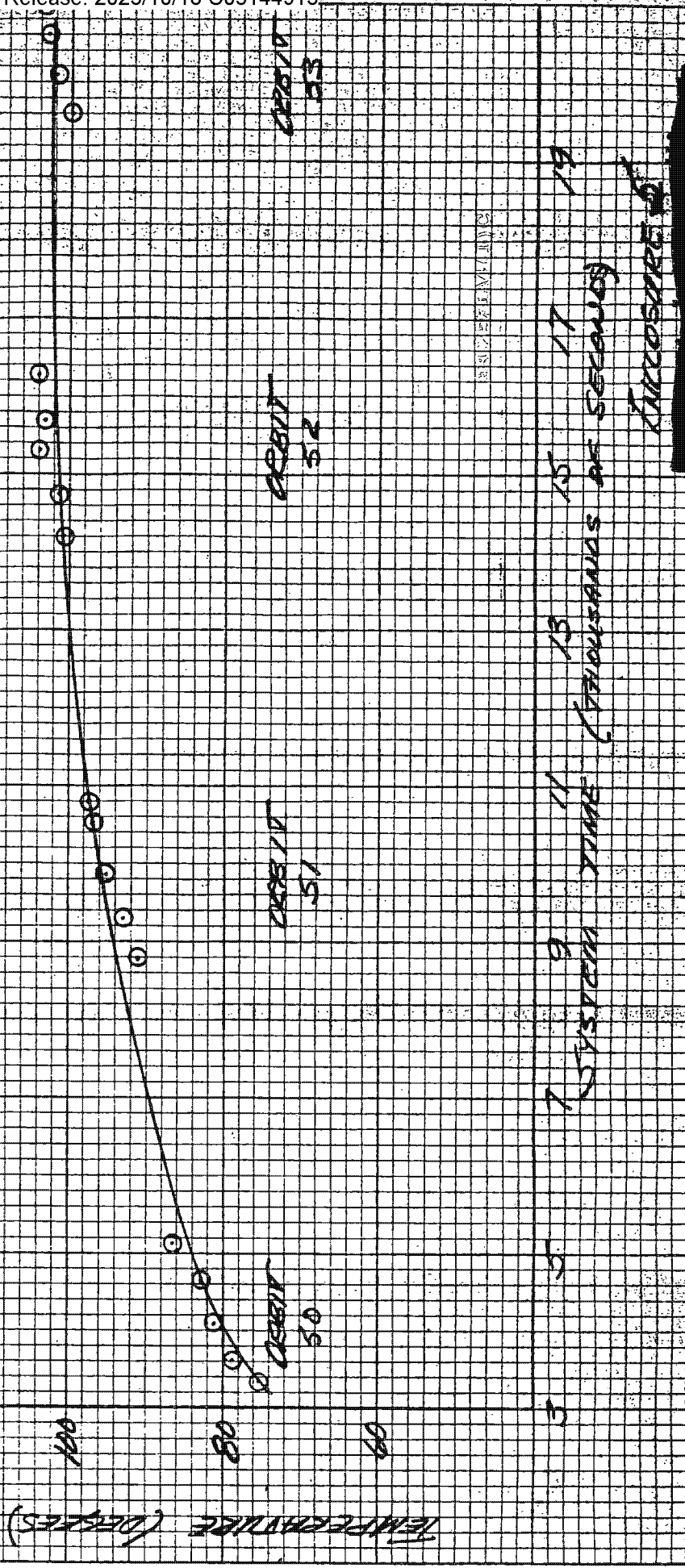
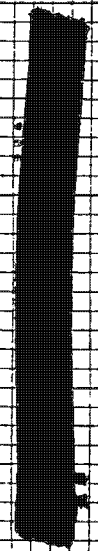

TEMPERATURE

SYSTEM TIME (THOUSANDS OF SECONDS)

ENCLOSURE

SECRET

KOE 10 X 10 TO THE INCH KEUFFEL & ESSER CO. BRIDGE, N.Y.

NR025X1A4(I)C

J-3 1174 DREAMBOAT BATTER
TEMP SENSITIVE CAPACITORS
(NO SELF HEATING CHARACTERISTICS)

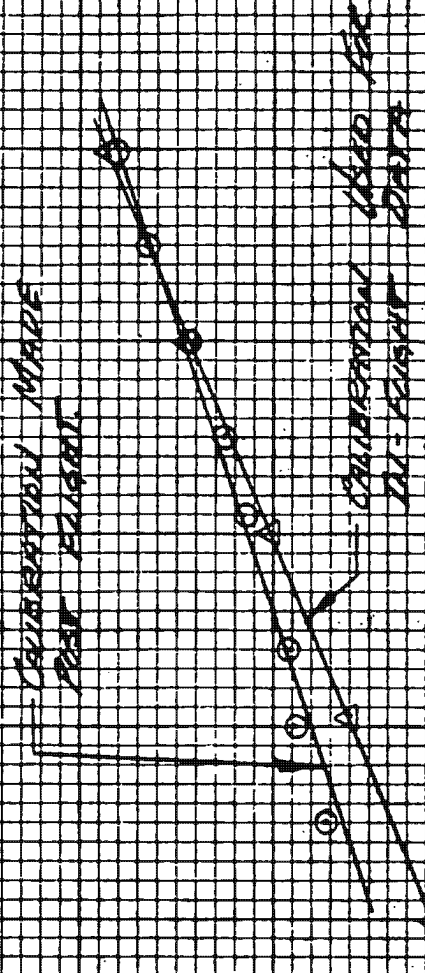

ENCLOSURE 10

ENCLOSURE 10

ENCLOSURE 10

~~SECRET~~

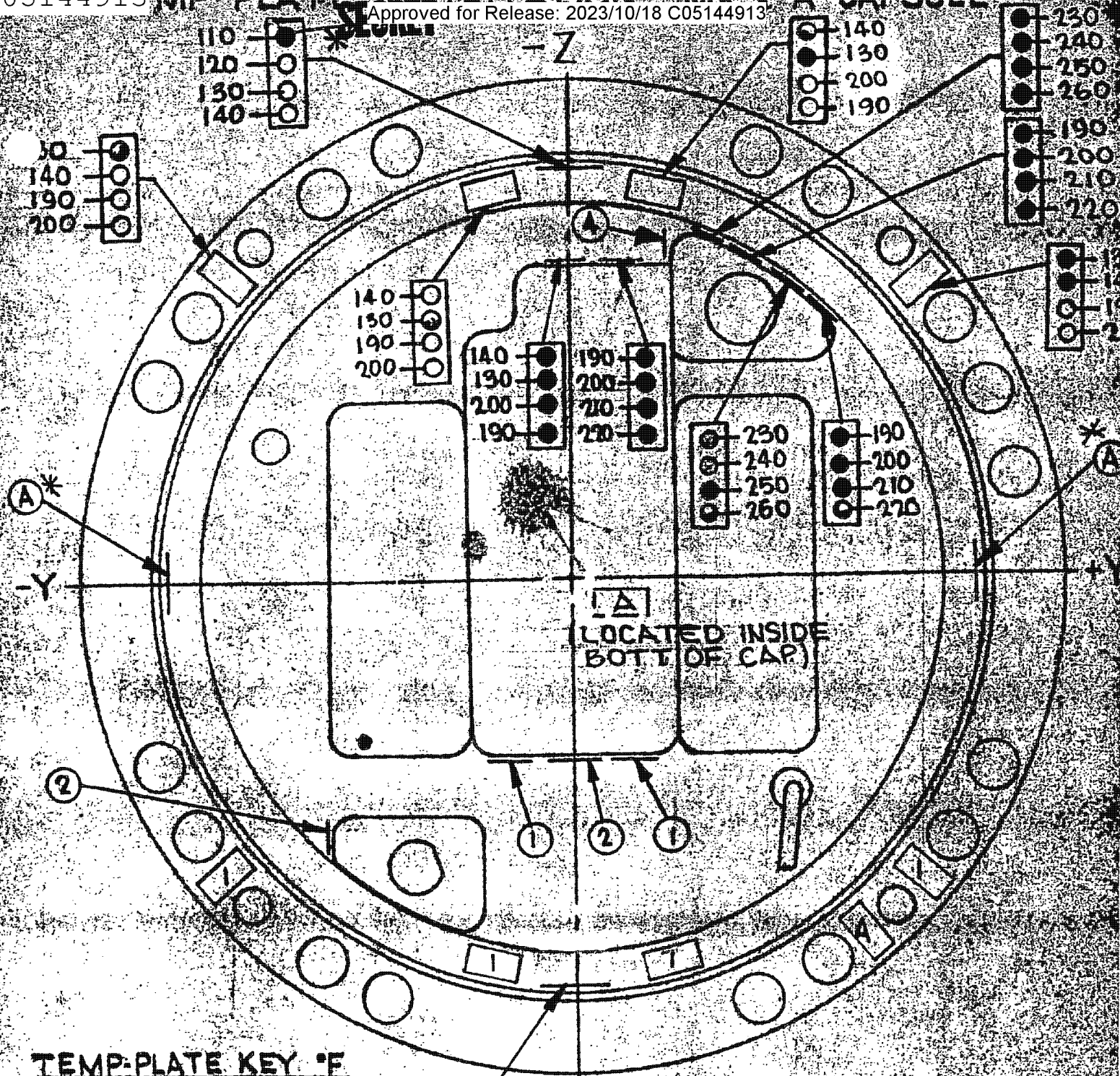

TEMP-PLATE KEY °F

- A - 110-120-130-140
- 1 - 130-140-190-200
- 2 - 190-200-210-220
- 3 - 230-240-250-260
- 4 - 270-280-290-300

* (A) +Z

LOOKING FORWARD
VEHICLE 1174

* LOCATED INSIDE
CAPSULE ON NOSE WALL

● INDICATOR TURNED BLACK
TEMP REACHED OR EXCEEDED
INDICATED LEVEL

J5 B

SECRET

ENCLOSURE 7

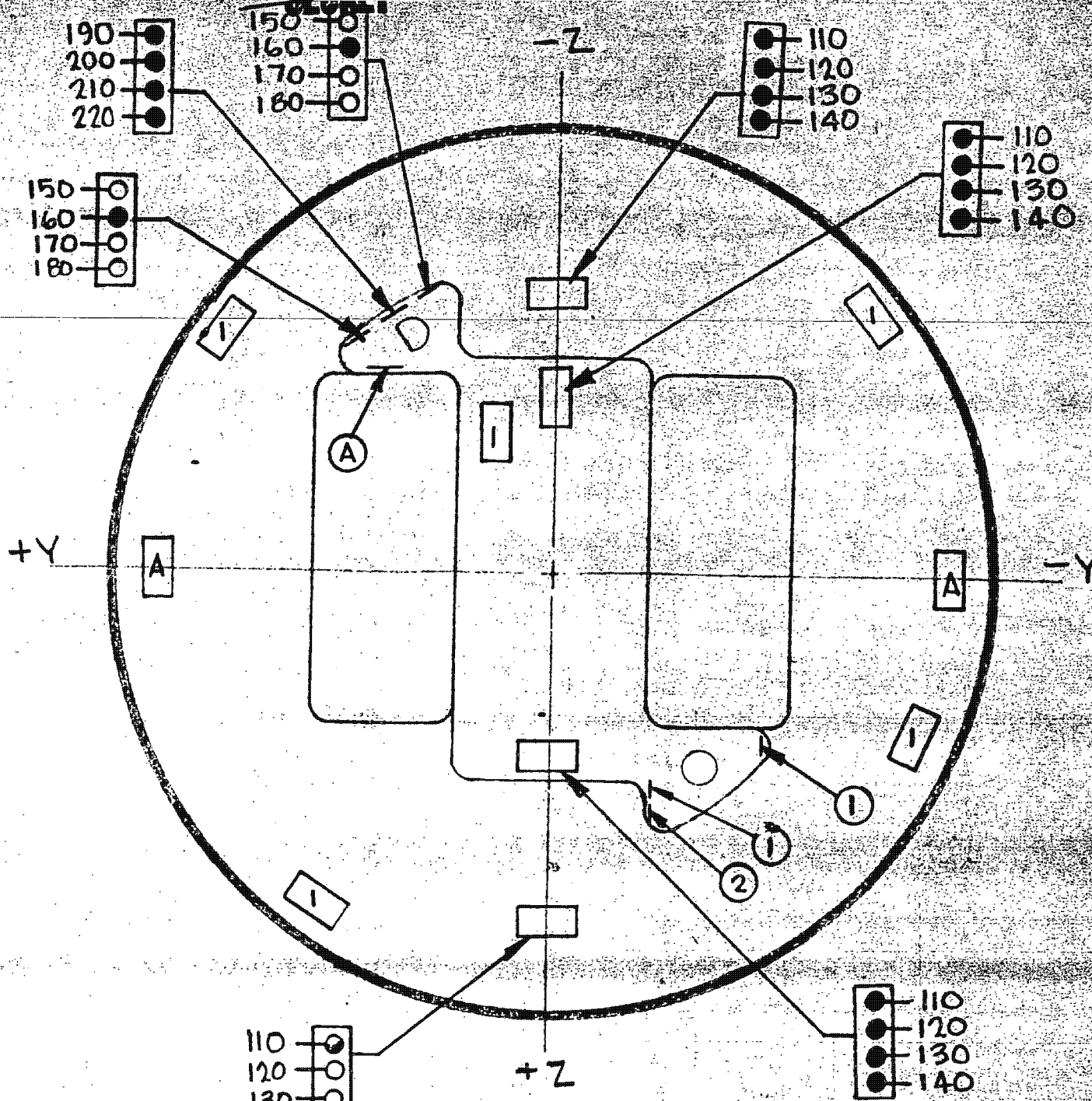

LOOKING AFT
 VEHICLE 1174
 USE OF TEMP-PLATES)

TEMP-PLATE KEY °F

- A- 110 · 120 · 130 · 140
- 1- 150 · 160 · 170 · 180
- 2- 190 · 200 · 210 · 220
- 3- 230 · 240 · 250 · 260
- 4- 270 · 280 · 290 · 300
- 5- 310 · 320 · 330 · 340
- 6- 350 · 360 · 370 · 380
- 7- 390 · 410 · 435 · 450

● INDICATOR TURNED BLACK
 TEMP REACHED OR EXCEEDED
 INDICATED LEVEL

~~SECRET~~ 15 B

ENCLOSURE 8

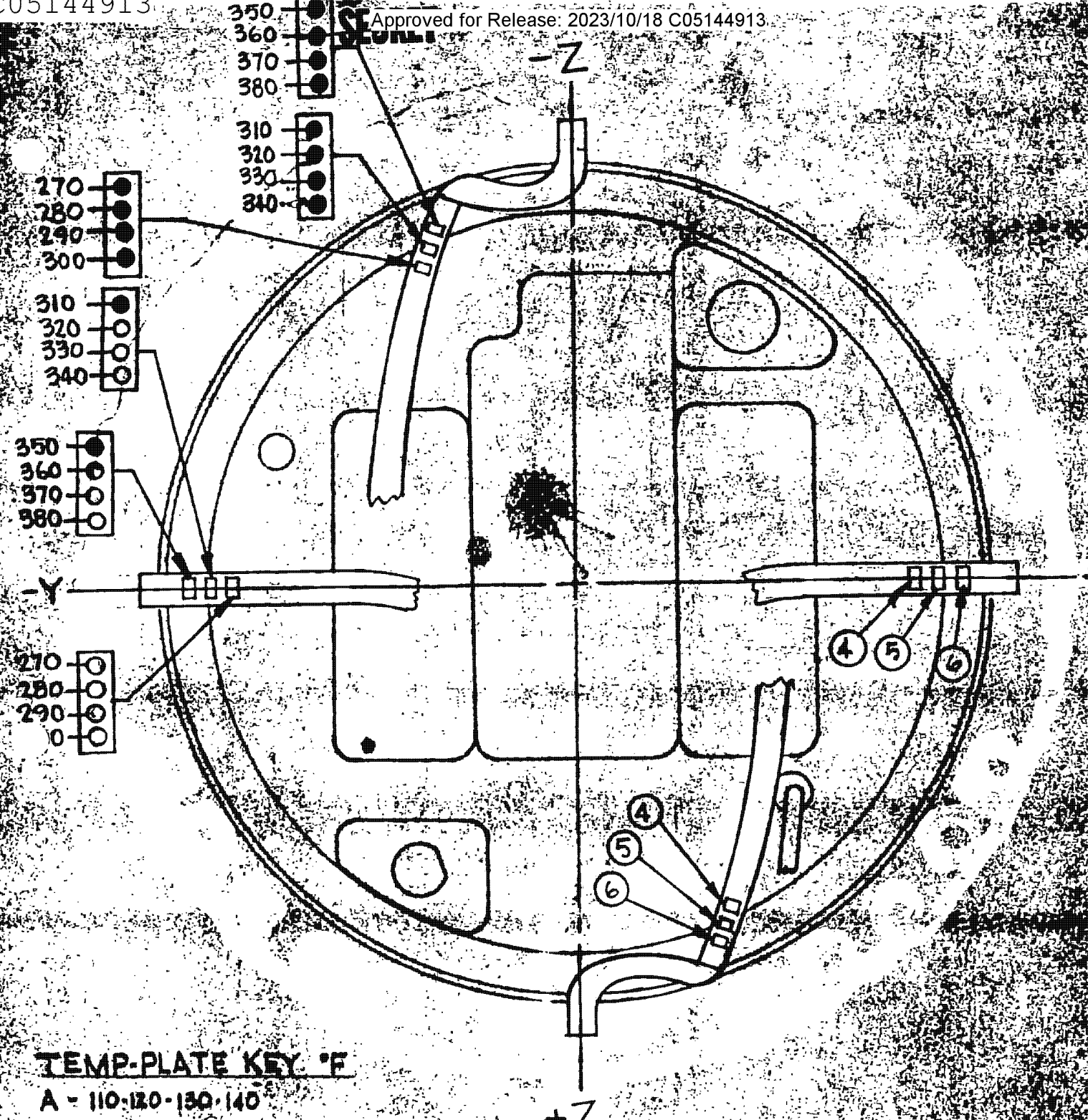

TEMP-PLATE KEY °F

- A - 110-120-130-140
- 1 - 150-160-170-180
- 2 - 190-200-210-220
- 3 - 230-240-250-260
- 4 - 270-280-290-300
- 5 - 310-320-330-340
- 6 - 350-360-370-380
- 7 - 390-410-435-450

**LOOKING FORWARD
VEHICLE 1174
USE OF TEMP-PLATES
ON PARACHUTE SHROUDS**

● INDICATOR TURNED BLACK
TEMP REACHED OR EXCEEDED
INDICATED LEVEL.

J5 B

SECRET

ENCLOSURE 9.

~~SECRET~~

NR025X1A4(I)C

J-5 1174 TEMPERATURE SUMMARY

NR025X1A1(I)C

SENSOR

Master

110

3	60	9	16	25	31	41	47	49	56	63	72	78	88	94	104	110
4	61	46	41	43	38	42	37	37	38	34	36	33	34	31	36	28
5	60	48	42	45	40	44	38	42	42	36	41	35	38	34	39	31
6	58	58	52	54	49	54	47	50	57	44	48	44	45	42	46	39
7	58	65	60	63	58	62	56	52	54	52	54	51	52	47	53	44
8	62	60	52	55	49	55	49	47	51	45	51	44	47	42	47	39
9	58	68	61	66	56	63	54	55	61	54	59	51	57	48	32	47
10	60	63	58	60	56	58	56	52	54	49	52	49	52	46	51	43
11	74	61	46	60	52	51	47	50	47	50	46	43	44	42	47	45
12	71	51	45	50	42	49	43	41	47	39	46	39	44	38	38	36
13	60	68	57	61	56	55	53	53	52	52	51	49	48	46	46	44

Slave

3	57	61	59	64	56	60	55	52	56	50	53	48	49	44	49	40
4	64	70	59	66	56	63	56	56	60	51	56	49	53	47	53	43
5	58	61	55	59	51	57	51	51	54	48	50	44	48	43	48	40
6	57	58	51	54	50	54	50	54	49	43	46	44	44	41	45	38
7	58	65	58	61	56	60	56	54	56	50	53	50	51	47	52	47
8	63	65	57	63	55	61	55	54	57	50	54	44	47	47	52	44
9	66	56	51	54	48	54	48	47	51	44	46	44	49	40	40	39
10	58	63	58	59	56	59	55	51	54	49	52	49	49	46	50	43
11	64	54	56	50	45	56	50	46	53	41	50	45	41	38	400	30
12	64	65	63	64	55	62	54	52	53	49	55	48	51	44	50	40
13	56	58	59	58	55	57	57	54	54	50	51	51	48	47	47	45

Supply Speed

1	62	55	31	53	49	51	49	48	48	45	48	44	46	42	45	39
2	63	60	46	57	52	54	51	51	51	46	58	45	47	42	47	39

ENCLOSURE 10

NR025X1A1(I)C

~~SECRET~~

~~SECRET~~

NR025X1A1 (I)C

NR025X1A4 (I)C

J-5 1174 TEMPERATURE SUMMARY

Sensor	L	9	16	25	31	41	47	49	56	63	72	78	88	94	104	110
<u>Fairing & Barrel No. 1</u>																
1	-	7	4	7	7	4	4	-15	1	1	4	4	1	4	1	4
2	-	-19	-28	-15	-28	-15	-28	-28	-3	-13	0	-10	-3	-7	-3	-4
3	-	0	-8	-8	-8	-8	-8	-14	35	35	19	35	13	48	16	43
4	207	30	27	30	27	30	20	20	39	62	36	52	27	52	27	41
5	222	43	34	40	27	34	21	18	40	43	37	40	27	30	27	18
6	235	37	43	37	42	31	37	11	40	43	37	40	27	30	27	18
<u>Barrel No. 2</u>																
1	147	59	73	56	64	53	62	59	50	50	43	46	37	37	37	26
2	235	-16	85	52	85	46	36	49	46	64	39	58	29	55	29	44
3	184	25	40	28	50	25	50	15	22	0	22	34	15	43	18	41
4	191	5	-4	5	-4	5	-1	10	2	-11	2	-8	-1	-4	2	-6
5	173	16	13	13	16	16	16	10	3	0	3	3	0	3	3	-5
<u>Cenic Adaptor</u>																
1	159	64	62	63	59	62	53	46	59	43	56	43	46	33	46	24
<u>Clock</u>																
1	94	68	64	70	64	68	64	63	64	56	64	58	60	54	63	51
2	90	64	58	63	58	64	60	58	58	52	56	50	56	48	56	44
<u>Thrustcone</u>																
1	-	29	19	23	15	20	15	13	36	33	36	35	36	32	36	32
2	68	43	29	30	26	31	23	25	42	40	42	40	40	37	39	36
<u>Stellar Index</u>																
2	82	46	36	39	33	36	33	29	46	36	42	39	39	36	42	30
<u>Recovery Battery No. 2</u>																
1	73	69	62	58	55	54	55	38	98	98	97	99	99	98	96	98
<u>Master Cassette</u>																
2	88	50	41	32	38	40	42									

NR025X1A4 (I)C

ENCLOSURE 11

~~SECRET~~

KE 10X10 TO THE INCH 359-5
KRUEFFEL & BISSER CO. MADE IN U.S.A.

1174-175 HANDED SYSTEM
TEMP SENSOR SELF HEATING

TEMPERATURE (DEGREES)



TEMPERATURE (DEGREES)

0 50 100 150 200 250
TEMPERATURE (DEGREES)

TEMPERATURE (DEGREES)



SECRET

K-E 10 X 10 TO THE CM. 350-14
KEUFFEL & ESSER CO. MADE IN U.S.A.

NR025X1A4(I)C

NR025X1A4(I)C

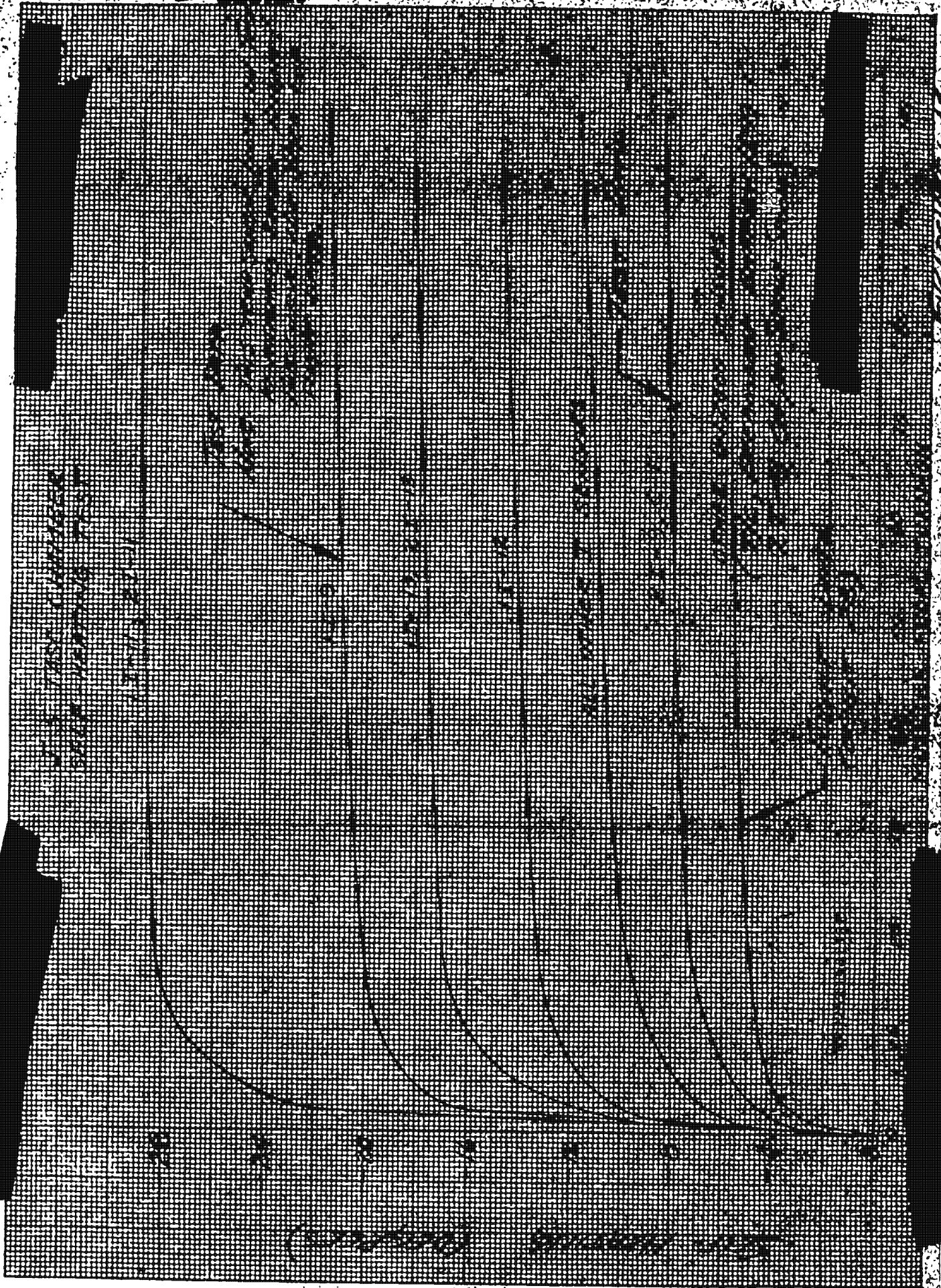

~~SECRET~~

"J" BOUND PROFILE TO SHOW APPLX.
TEMP SENSOR LOCATIONS

NR025X1A4(I)C

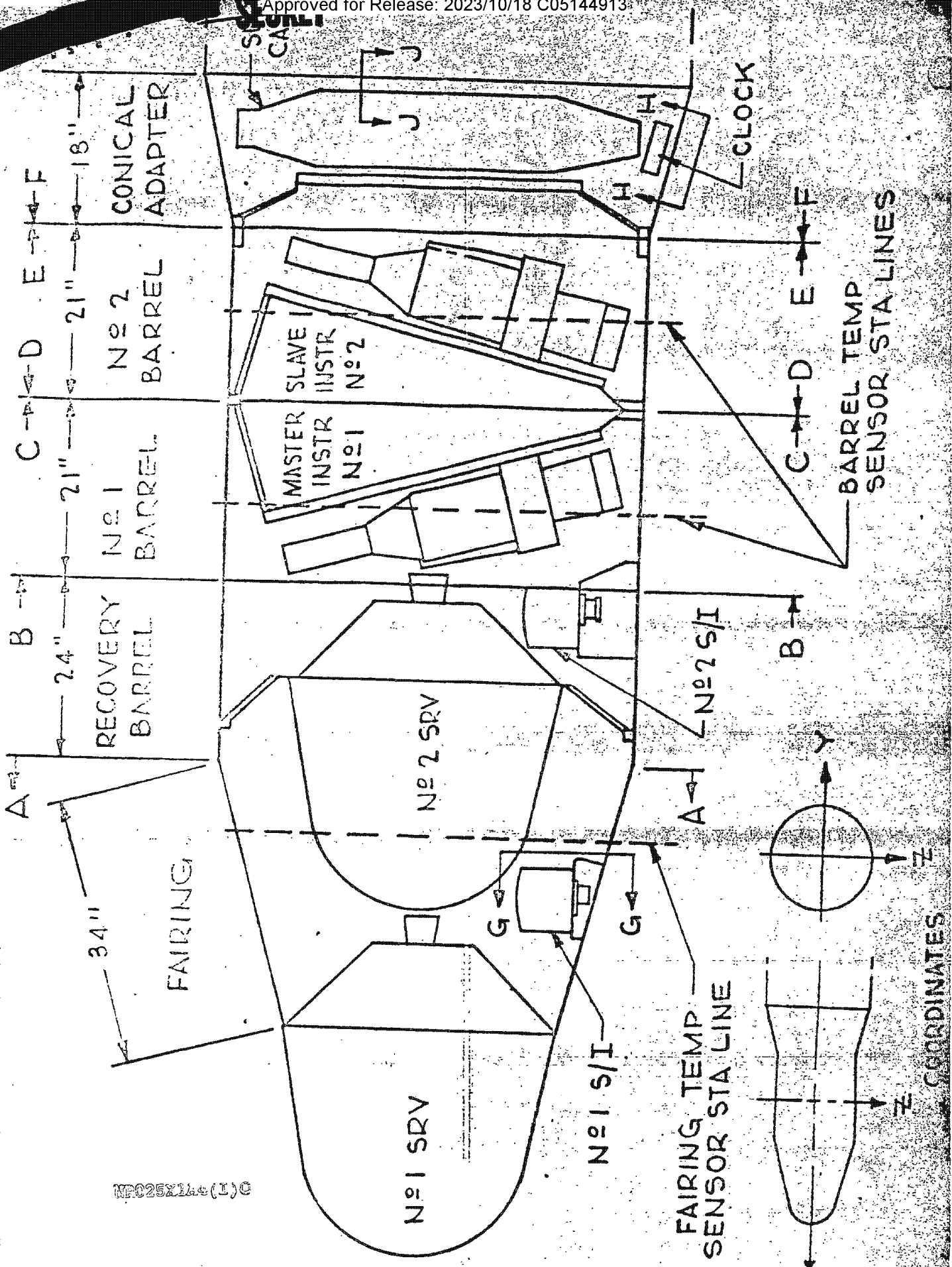

NR025X1A4(I)C

SECRET

ENCLOSURE 14

SHT 1 OF 7



NR025X1A4(I)C

FAIRING TEMP SENSORS

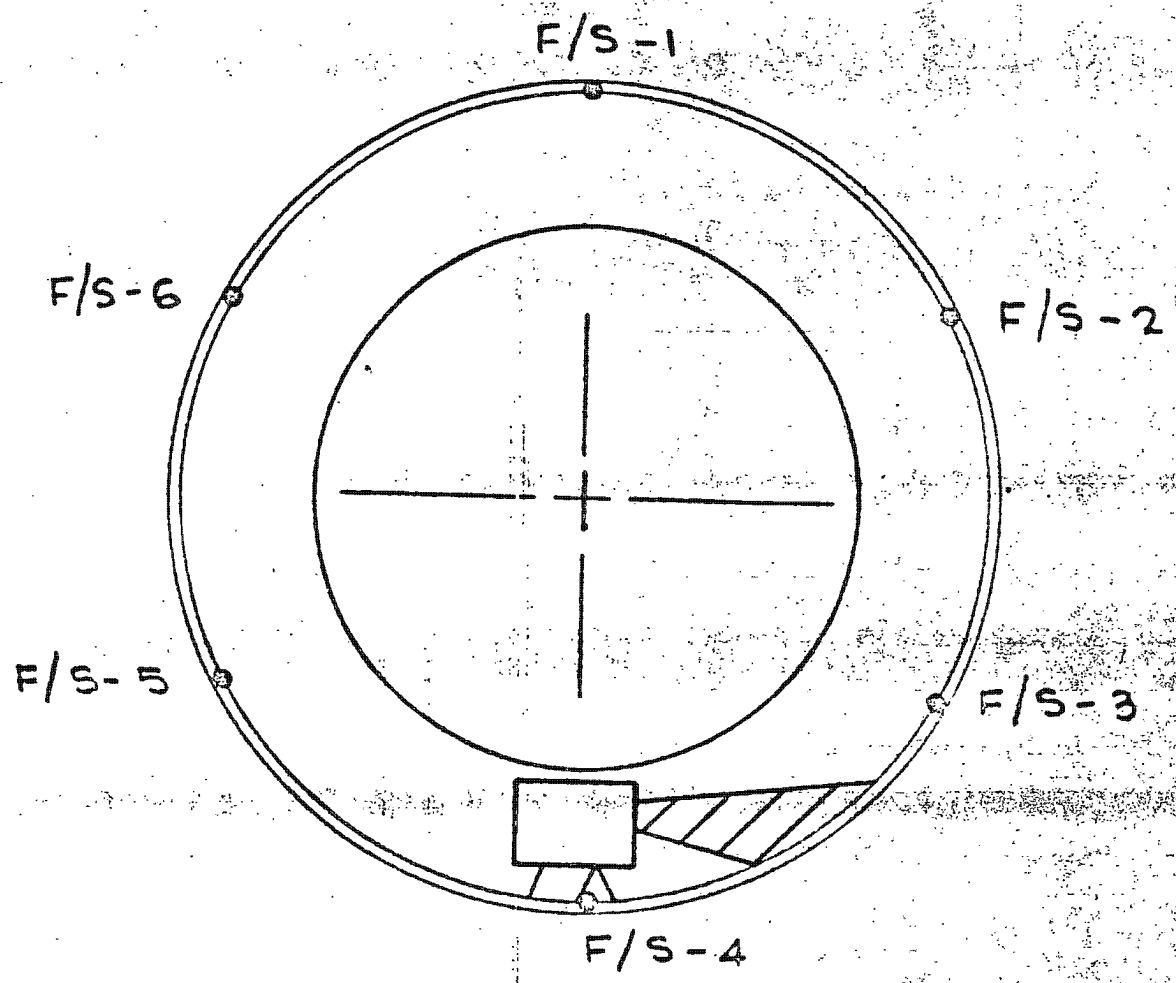

VIEW A-A
LOOKING FORWARD

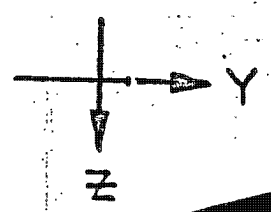

NR025X1A4(I)C



ENCLOSURE 15

~~SECRET~~

NR025X1A4(1)C

NO 1 & NO 2 INSTR TEMP SENSORS (FRONT FACE) NO 1 & NO 2 BARREL TEMP SENSORS (SKIN)

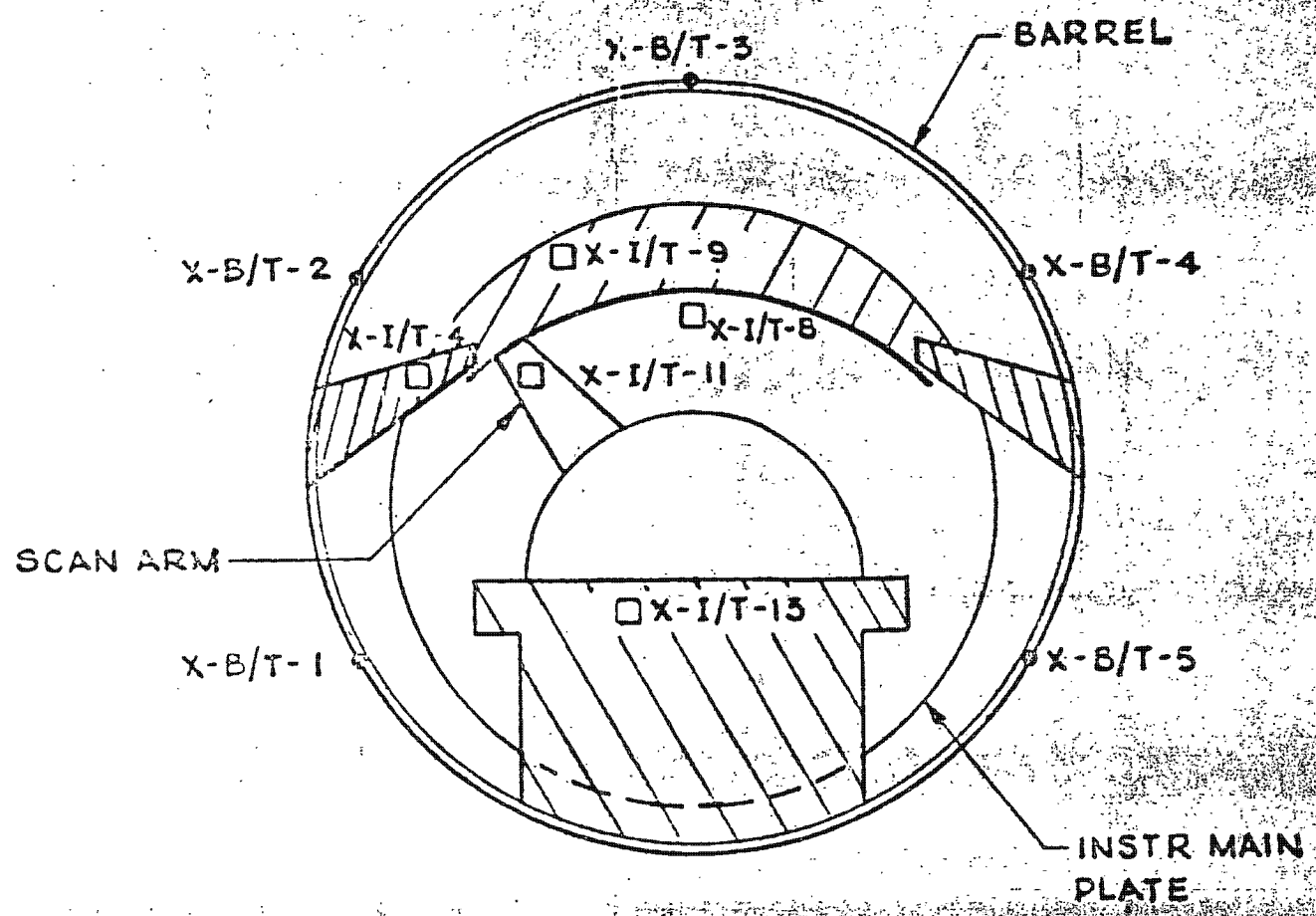

VIEW B-B & F-F

INSTR NO 1 LOOKING AFT.
INSTR NO 2 LOOKING FWD

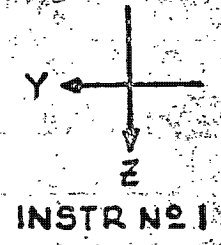
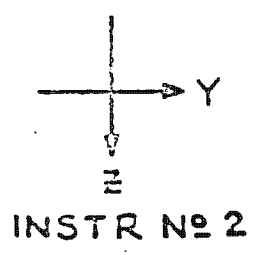

KEY:

SEE KEY, PAGE 4 OF 9

NR025X1A4(1)C

ENCLOSURE 16
SHT 3 OF 7

SECRET

REF ID: A4(I)C

№ 1 & № 2 INSTR TEMP SENSORS (BACKFACE) № 1 & № 2 BARREL TEMP SENSORS (SKIN)

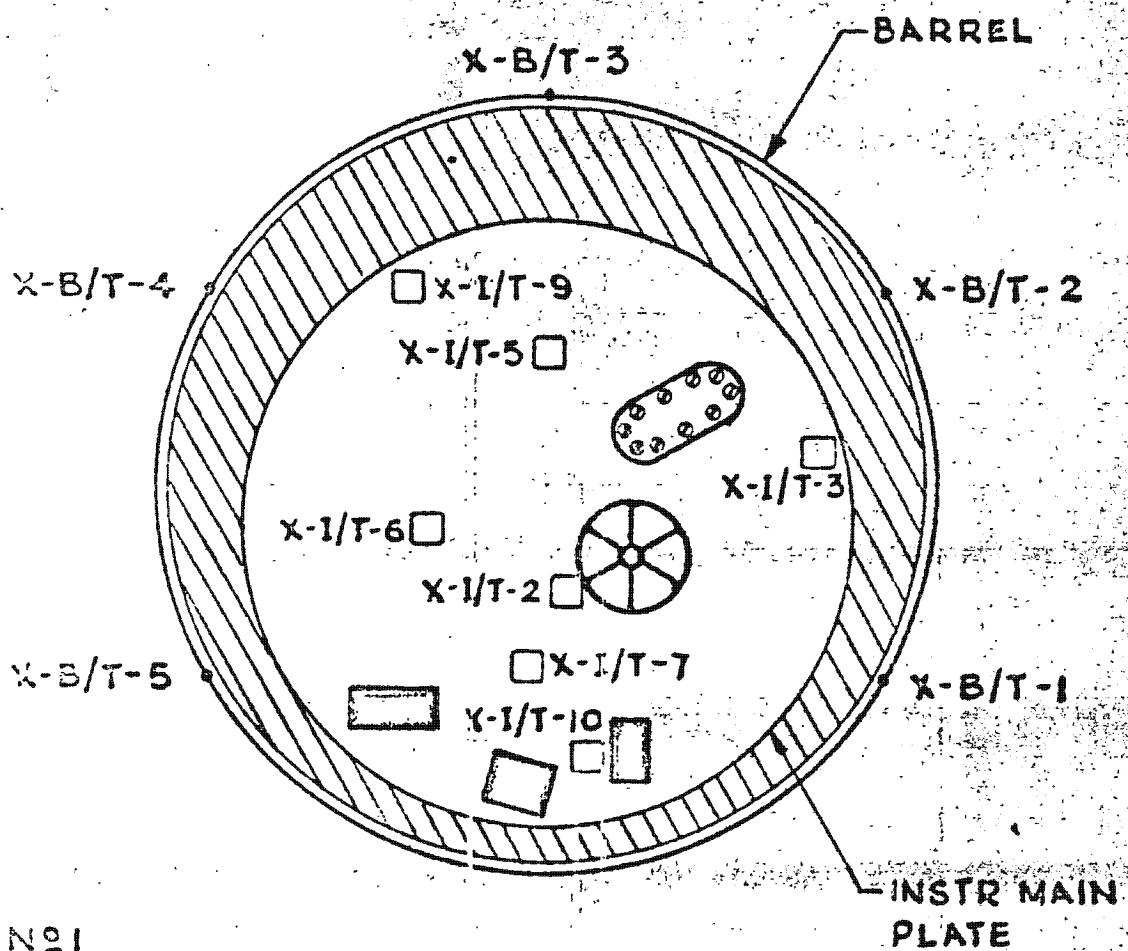

INSTR № 1

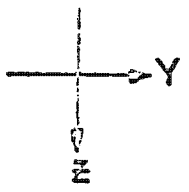

VIEW C-C & D-D
 INSTR № 2 LOOKING AFT
 INSTR № 1 LOOKING FWD

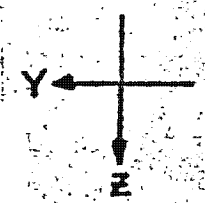

KEY:

X DENOTES № 1 OR № 2 INSTR OR BARREL
 e.g. X-I/T-6 IS № 1 OR № 2 INSTR - INSTR TEMP
 SENSOR № 6
 X-B/T-4 IS № 1 OR № 2 BARREL TEMP
 SENSOR № 4

ENCLOSURE 17
SHT 4 OF 7

~~SECRET~~



NR025X1A4(I)C

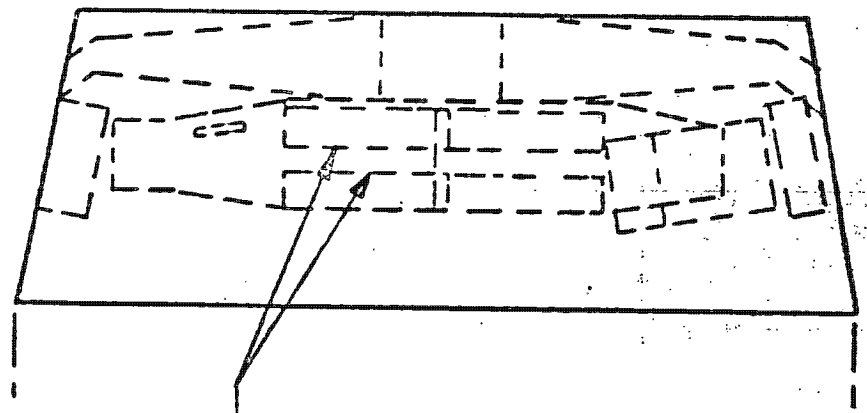

SIDE VIEW
SHOWING SPOOLS

NR025X1A4(I)C

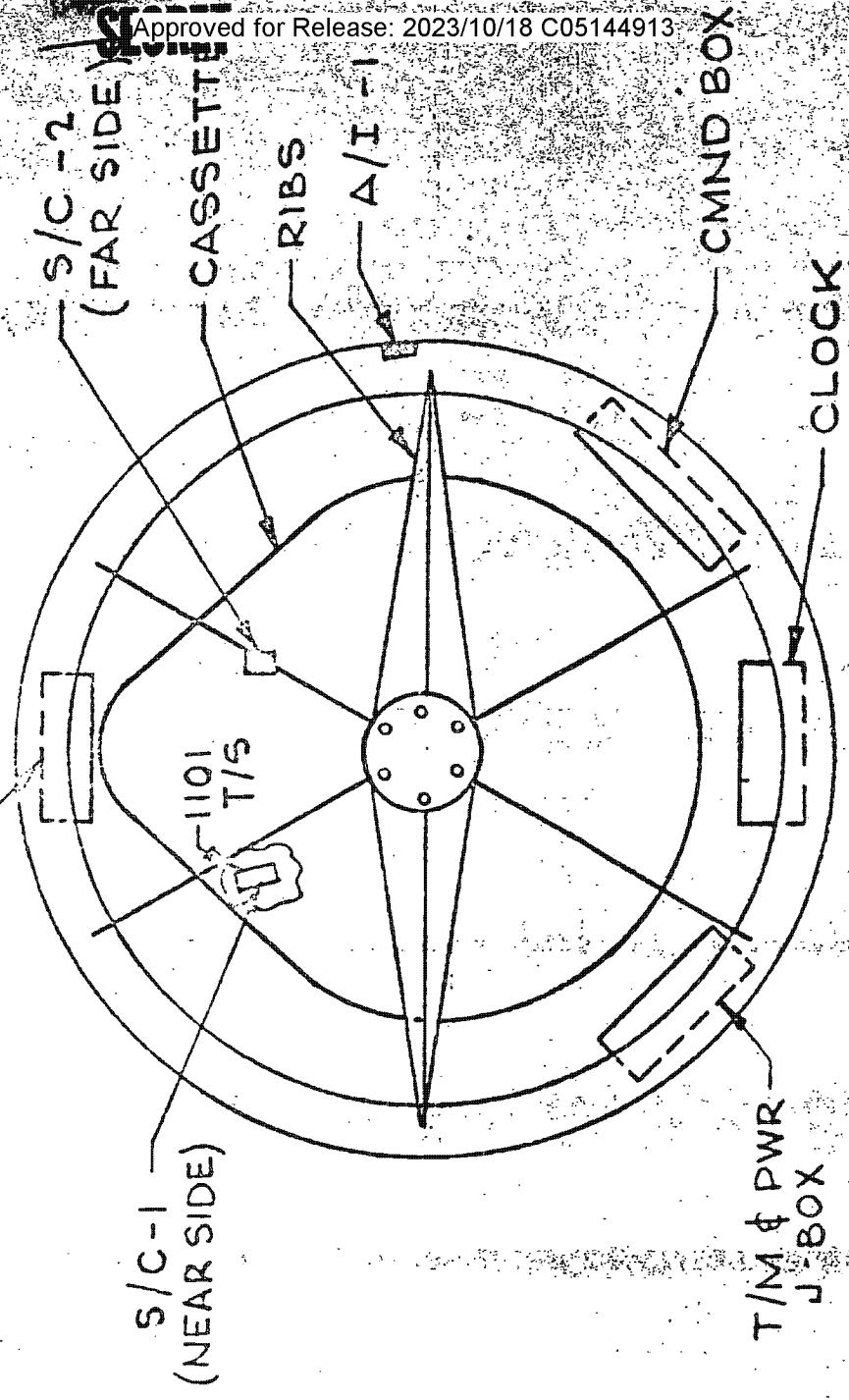

VIEW E-E
SUPPLY CASSETTE
LOOKING AFT

SECRET

ENCLOSURE 18



~~SECRET~~

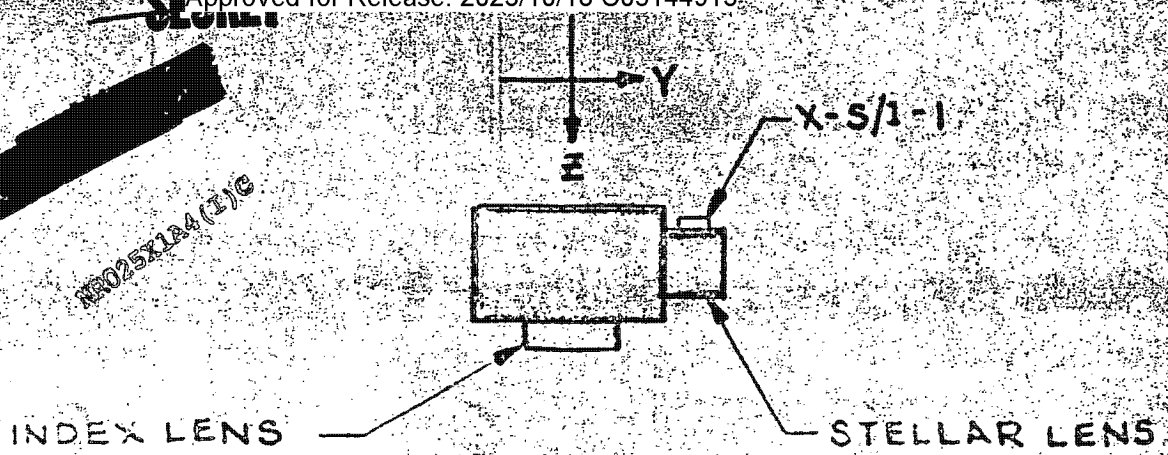
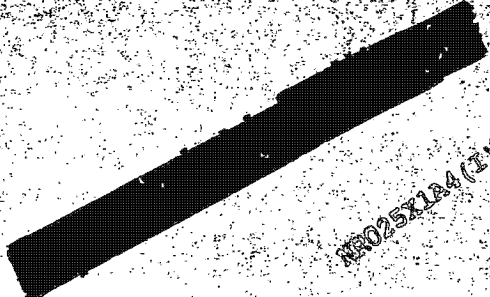

VIEW G-G
S/I TEMP SENSOR

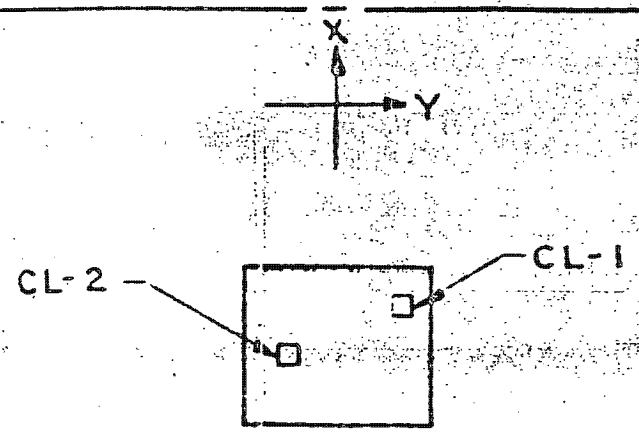

VIEW H-H
CLOCK TEMP SENSOR

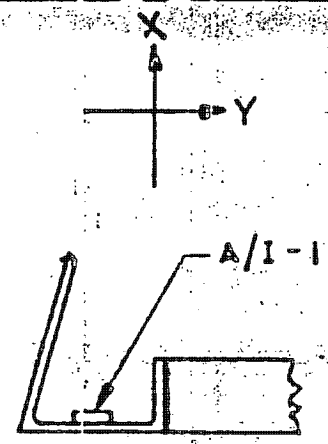

VIEW J-J
INTERFACE TEMP SENSOR
(SENSOR ON -Y AXIS)

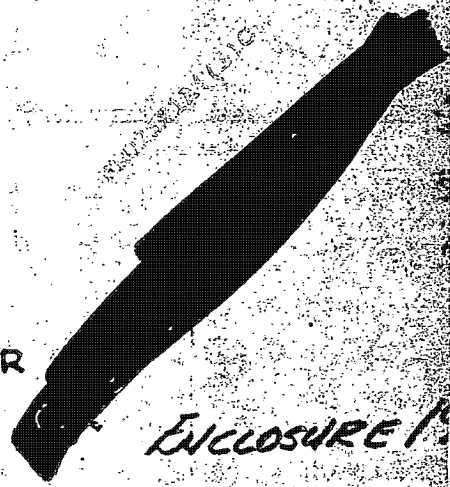

~~SECRET~~

REF ID: A66666

NO. 2 SRV THRU SHIELD

RECOVERY BUCKET

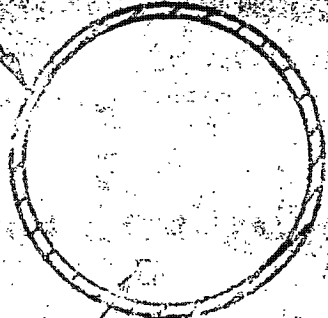
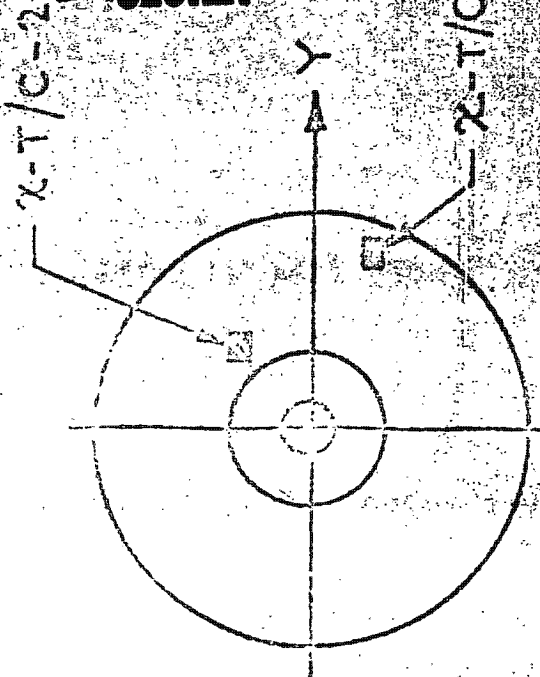
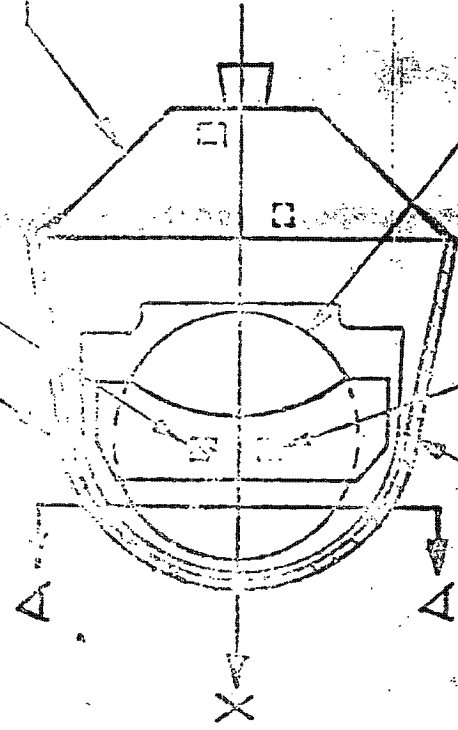

SECTION A-A

KEY:

X DENOTES NO. 1 OR NO. 2 SRV

NO. 9.

X-T/C-2 IS

NO. 2 SRV - THRUST CONE TEMP SENSOR - 2

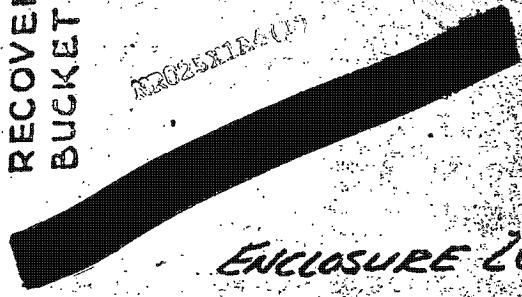

ENCLOSURE 20

SECRET

K&E 10 X 10 TO THE INCH KEUFFEL & ESSER CO. MADE IN U.S.A. 359-5

SKIN T AND INTERNAL TEMPERATURES VS. ORBIT NO.

J-5 VEHICLE 1174

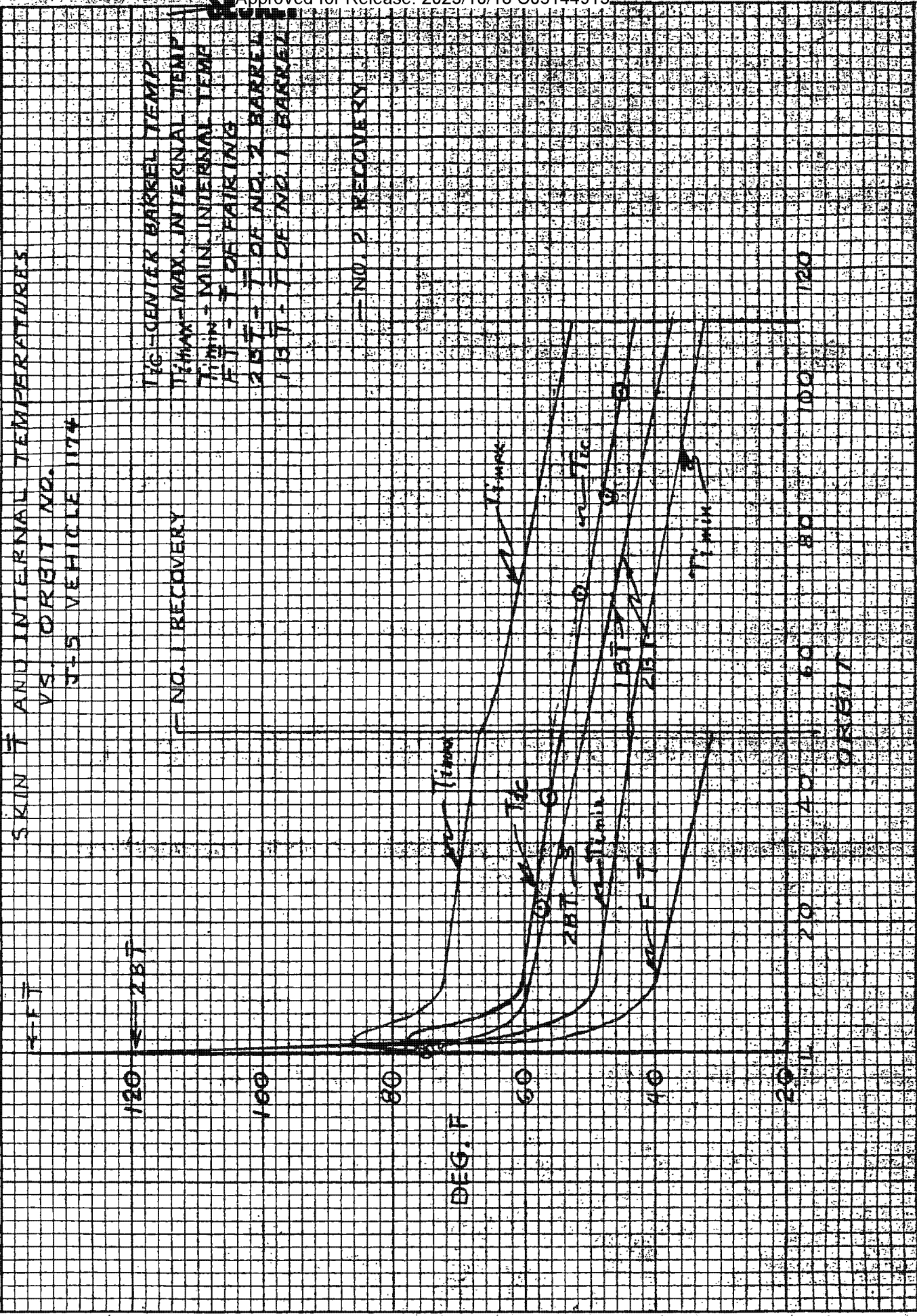

~~SECRET~~

ENCL. 21

KY 10X10 TO THE INCH KEUFFEL & ESSER CO. MADE IN U.S.A. 359-5

PLT 1174 (15-03)
AS VS REV NO.

REV 1 DRAIN PARAMETERS
 $h_p = 89.9 \text{ mm}$
 $E = 0.02002$
 $L = 24.97 \text{ mm}$
 $T = 90.92 \text{ mm}$

INJECTION TIMES
21.45 mm
15 FEB 1984

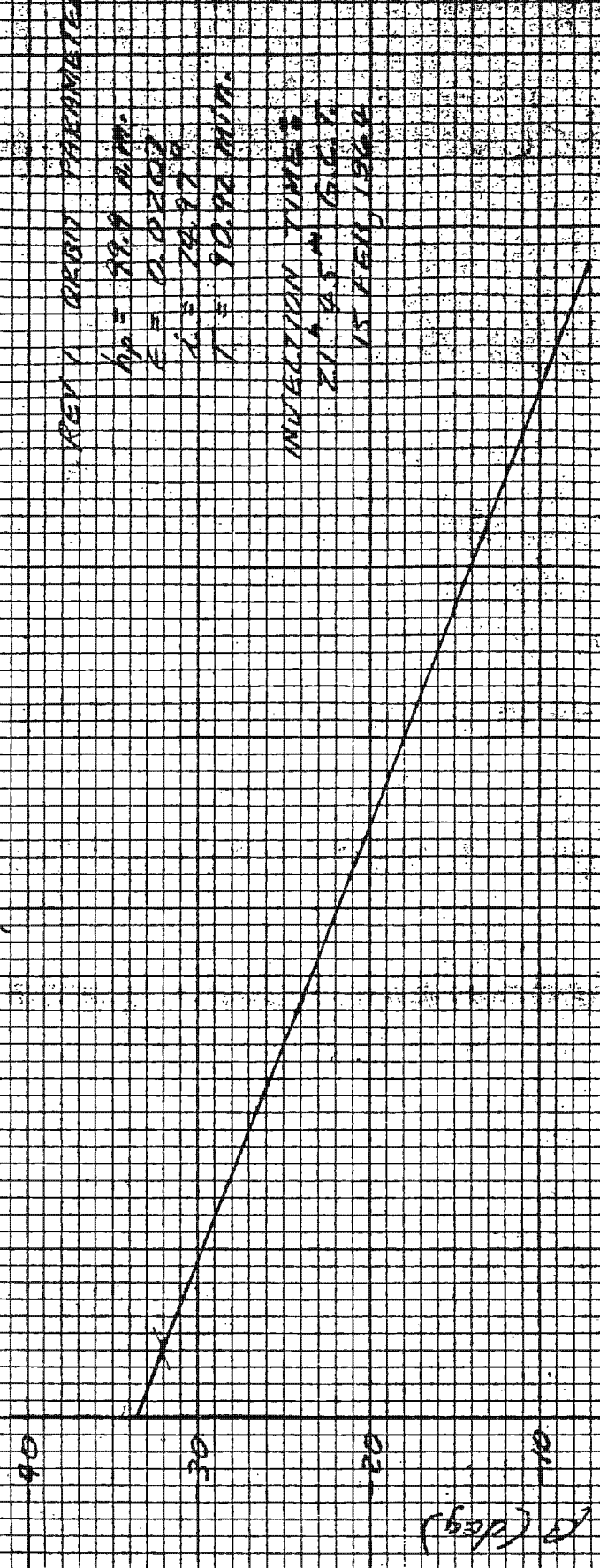

REV NO

~~SECRET~~

ENCL. 22

KOE 10 X 10 TO THE INCH
KAUFFEL & EBER CO. MADE IN U.S.A.

SKIN T AND BARREL CENTER TEMP
VS. SUN ANGLE
J-5 VEHICLE 1174

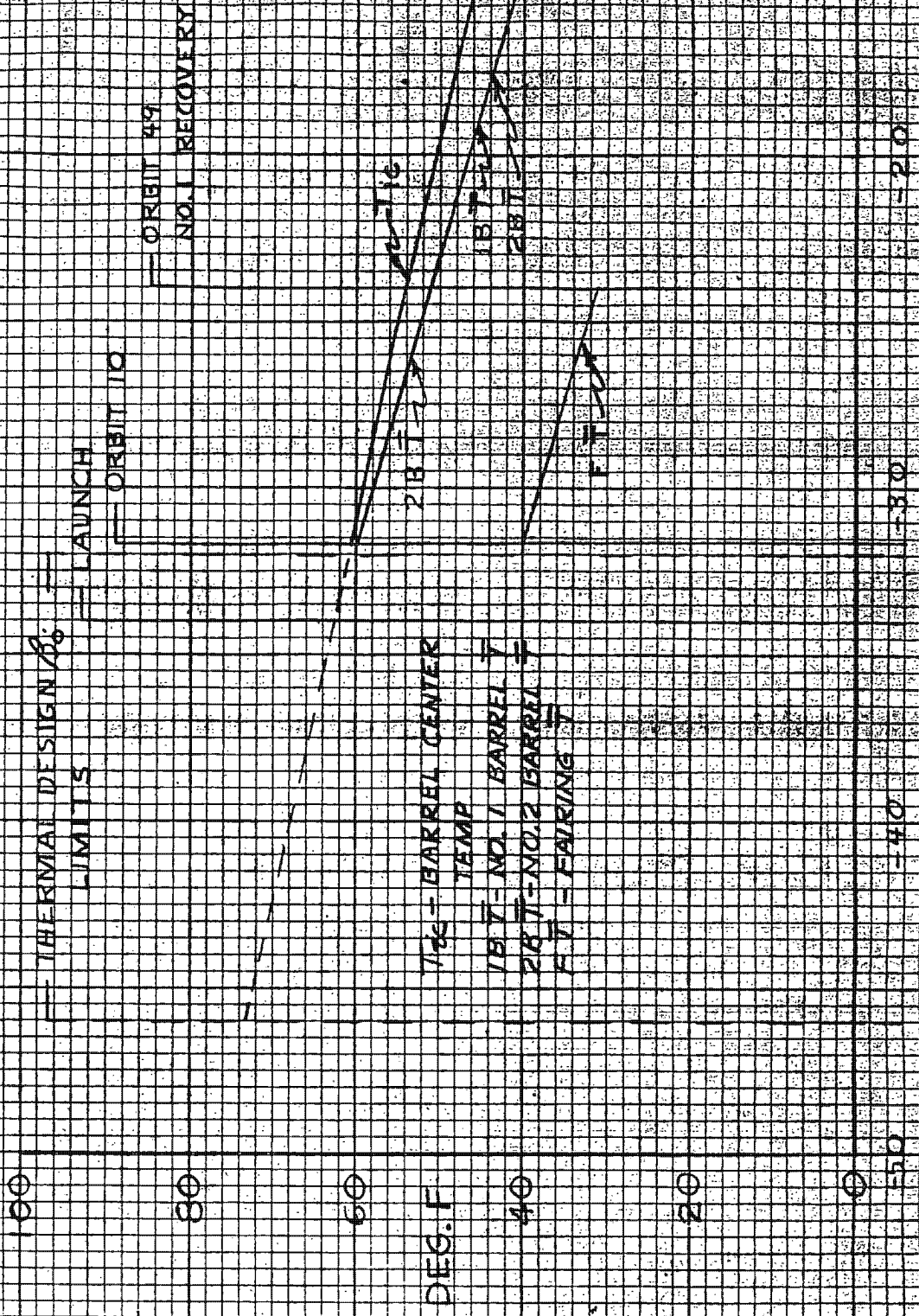

10-1-DES

~~SECRET~~